



# **B**RAKE **C**ONTROL **U**NIT

## **V3 TSD (Two Step Delay) BRAKE CONTROL UNIT**



The Sibre V3 TSD Brake Control Unit has been designed specifically for use in conveyor drive applications where full braking force needs to be applied in two stages to prevent mechanical damage to the drive or conveyor belt.

The V3 BCU is designed to be used in conjunction with the SIBRE range of SHI Spring applied Hydraulic calliper disc brakes and can be used to control generally up to 4 brakes depending on their distance from the BCU.

The V3 BCU consists of the following main components:

- 3 kW 3 Phase Electric Motor
- Pump
- 0.75 l Accumulator
- Manifold with control valving
- Level switch
- 25L Aluminium Tank, Filler Breather and Sight Level gauge
- Digital P/switch with two adjustable set points (S1 & S2)
- Electrical components terminated into separate junction box

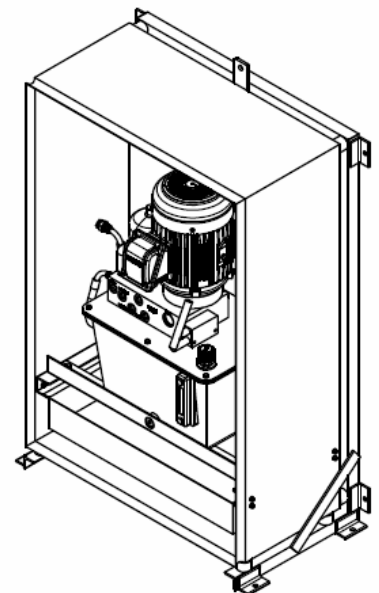
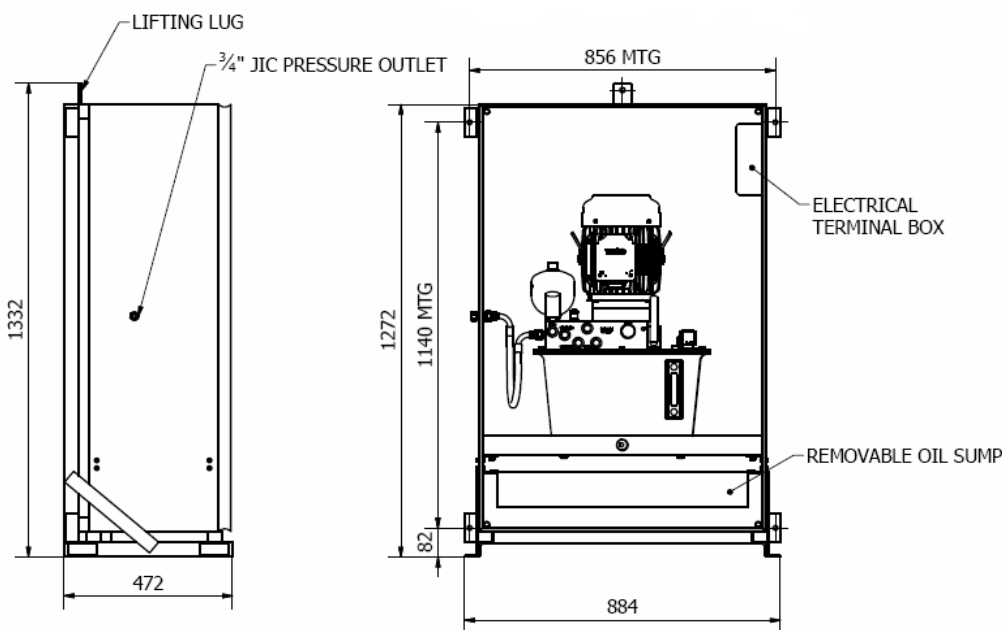

DRAWING IS INDICATIVE AND DOES NOT SHOW CABINET DOOR.

## Technical Data

- |                                         |                                              |
|-----------------------------------------|----------------------------------------------|
| • Tank volume                           | 25 litres                                    |
| • Ambient temperature ranges            | -15°C ... +40°C in standard version          |
| • Humidity                              | < 90%                                        |
| • Recommended operating fluid           | ISO VG 46 Hydraulic Mineral Oil              |
| • Protection class                      | IP66                                         |
| • Max. no. of operating cycles per hour | 30                                           |
| • Motor supply voltage range            | rotating ccw (fan end)<br>50 Hz / 380-420 V  |
| • Valve voltages                        | 24V DC, 240 VAC (Standard) others on request |
| • Flow capacity per valve               | 35 l/min at $\Delta p$ 10 bar                |
| • Envelope size                         | 1272 x 883 x 472mm                           |

Type	Suitable for					
V3 E	SHI 102	SHI 101	SHI 75-2	SHI 75-1	SHI 52	SHI 51
V3 A	SHI 104	SHI 103	SHI 75-4	SHI 75-3		
V3 B	SHI 251	SHI 201	SHI 105	SHI 75-5	SHI 53	
V3 D	SHI 252	SHI 231	SHI 106	SHI 75-6		
V3 C	SHI 232	SHI 202	SHI 107	SHI 54		
	CB8-H					

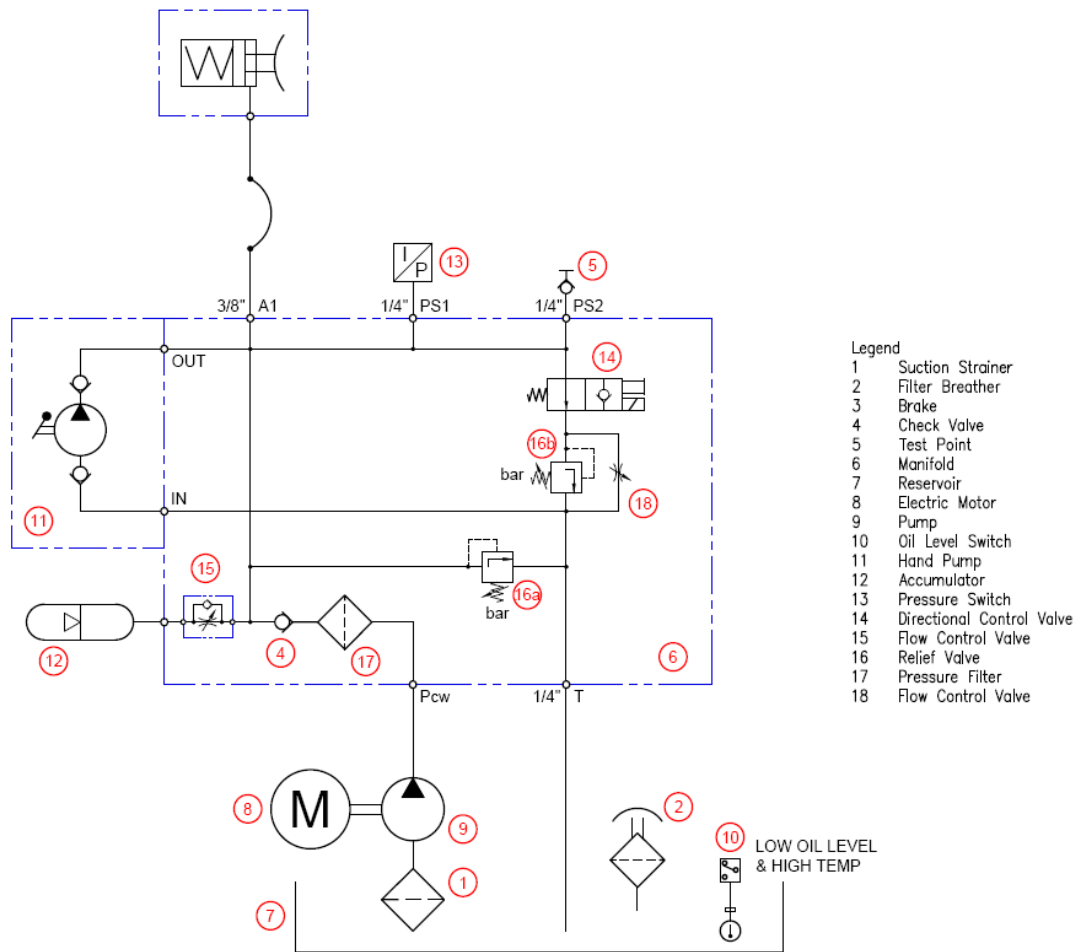

Type	Pressure switch		Pressure relieve valve setting (DBV)	Release pressure	Pump capacity	Motor power
	min	max				
	bar		bar	bar	l/min	kW
V3 E	55	70	85	55	20	3.0
V3 A	80	95	110	80	20	3.0
V3 B	120	135	150	120	13	3.0
V3 D	145	160	175	145	9	3.0
V3 C	175	190	205	175	9	3.0