

Electrohydraulic Thrusters ELHY®

EB Series (120 – 6300 N)
Product Specifications



EMG-ELTMA
Hebezeuge Oschersleben GmbH



The Compact Alternative

Wherever linear movements are to be carried out on or in equipment, machinery or devices, the electrohydraulic linear drive (ELhy) is the ideal answer, above all, if reliable drive solutions are to be implemented which can hardly be obtained by means of pneumatic or hydraulic systems. The electrohydraulic linear drive can be easily modified and used in a large variety of applications, making it the ideal, compact alternative.

There is a large variety of applications for ELhy devices in all spheres of industry ranging from force amplification, flap adjustment and actuation of barriers to valve control, actuation of clutches and feed positioning. A major field of application in lifting and handling processes is the actuation of machine brakes of various designs. The advantages of electrohydraulic actuation as compared to magneto-electric brake actuation are undisputed and unsurpassed from the point of view of safety.



Laubag open-cast mine at Nochten, bucket wheel excavator SRs 6300 + loading unit VR 156.12 equipped with 50 ELHY units



Laubag open-cast mine at Nochten, bucket wheel drive SRs 6300 equipped with 3 ELHY units, version EB 320/100 c320 SZm



KBE Gernsheim, double-link level luffing crane with 14 ELHY units

The Elhy Series 'EB' comprises a complete range of devices for actuating forces from 200 N to 3200 N in useful grading. The devices are available in the following basic versions:

- Standard series
- Series in compliance with DIN 15430
- Special versions following DIN 15430.



Kali und Salz AG, Unterbreitzbach works, conveyor drive, disk brake RST 2 with ELHY version EB 1250 – 60 Lm 2



Kranbau Eberswalde, balancing crane 6 t x 40 m equipped with 4 ELHY units EB 220 – 50/2 (at YBBS, Austria)

Mechanical Design

The electrohydraulic thruster (Elhy) comprises all basic components of a hydraulic system in one single packaged unit. It consists of a hydraulic pump with electric drive motor, a closed hydraulic guide system and the working cylinder with piston and lifting rod and converts electric energy by way of hydraulics into mechanical straightline movements.

The Elhy devices are available in three different series of uniform functional principle, internal setup, and outer appearance. Since the only difference between the series are the mounting dimensions, the data given in this catalogue apply to all three series.

The motor casing houses the stator of the drive motor which is designed as a three-phase asynchronous squirrel-cage motor. The electric connection is via the terminal box which seals the motor casing tightly. The feet cast en bloc with the motor casing serve to mount the Elhy device. On the one hand, the rotor with shaft is supported in the motor casing, on the other hand in the end shield. The blade wheel of the pump is mounted on the shaft. The guide cylinder with piston which moves axially is situated above the blade wheel. The device is filled with hydraulic fluid up to the level of the inlet opening. In the version which is equipped with pull-back springs, the latter are accommodated between the piston and the bottom of the guide cylinder.

The adjusting spring (standard series) or attenuation spring (series in compliance with DIN 15430 including special versions following DIN 15430) is mounted on the

lifting rod of the Elhy device. The connecting bolts of the adjusting spring, e.g. for connecting the brake linkage, are located at the same level as the bore in the lifting rod so that height of installation h_1 is obtained in line with the basic design.

The connecting butt strap of the attenuation spring has the same dimensions as the pertinent lifting rod head so that the assembly dimensions are identical for devices with and without attenuation spring.

Elhy devices can be equipped with inductive or mechanical switching elements thus allowing supervision of release and/or closing positions of the brake as well as any wear of brake linings.

Note:

The items shown in the sectional drawings can be ordered under these part numbers as spare parts. In addition, the exact type designation of the Elhy device should be indicated together with the number of the device, if possible.

- 1.21 Motor casing
- 1.22 Stator
- 1.23 Locking plate
- 1.40 Rotor
- 1.41 Radial deep groove ball bearing
- 1.42 Compensation washer for ball bearing
- 1.50 End shield
- 1.51 Radial deep groove ball bearing
- 1.60 Impellor
- 1.62 Cover plate
- 1.63 Top end shield
- 1.64 Cover plate
- 1.70 O-ring
- 1.80 Screw plug with packing ring

- 1.90 Bolt
- 2.10 Cylinder jacket
- 2.20 Lifting rod
- 2.21 Lifting rod head
- 2.30 Piston
- 2.31 Seal strip
- 2.40 Pull-back spring
- 2.50 Sealing system of lifting rod, compl.
- 2.51 Scraper ring
- 2.52 Retainer
- 2.53 Special rotary shaft seal
- 2.70 Guide cylinder
- 2.72 Regulating plug
- 2.73 Valve
- 2.74 O-ring
- 2.80 Seal
- 3.00 Terminal box, compl.
- 3.10 Terminal box frame
- 3.11 Special seal
- 3.20 Terminal board, compl.
- 3.30 Terminal box cover
- 3.50 Compressed gland
- 4.00 Adjusting spring, compl.
- 4.10 Spring pipe
- 4.20 Spiral spring
- 4.30 Spring plate
- 4.40 Stud bolt including hexagon nut with clamping element, washer and lock nut
- 5.00 Attenuation spring, compl.
- 5.10 Cap
- 5.20 Connecting butt strap
- 5.30 Strap
- 5.40 Spiral spring
- 5.50 Stud bolt including hexagon nut with clamping element, washer, lock nut and circlip

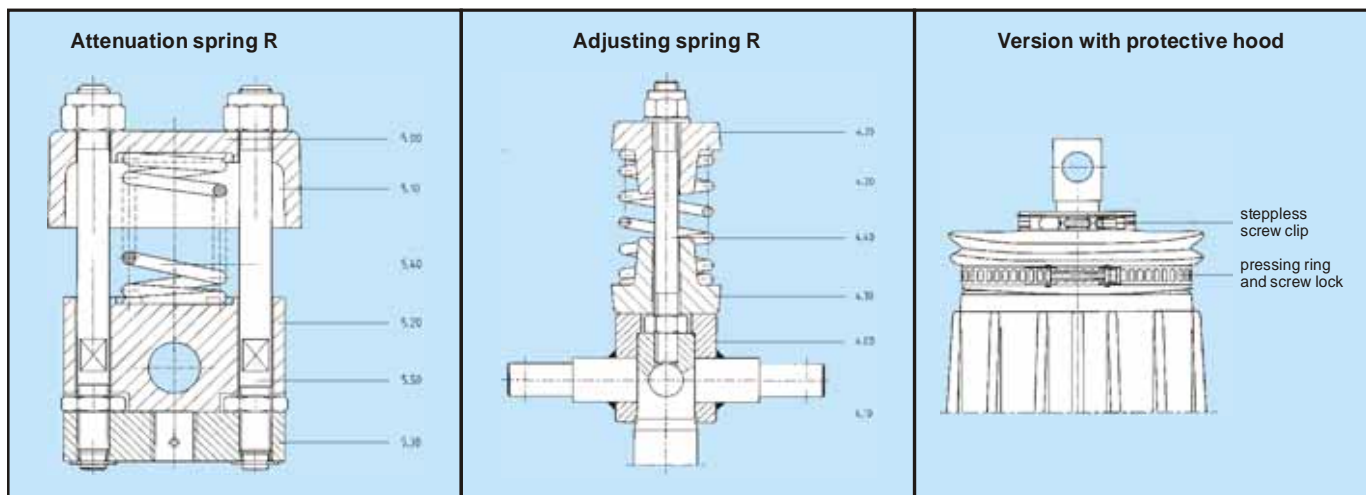

EB 300 – 50

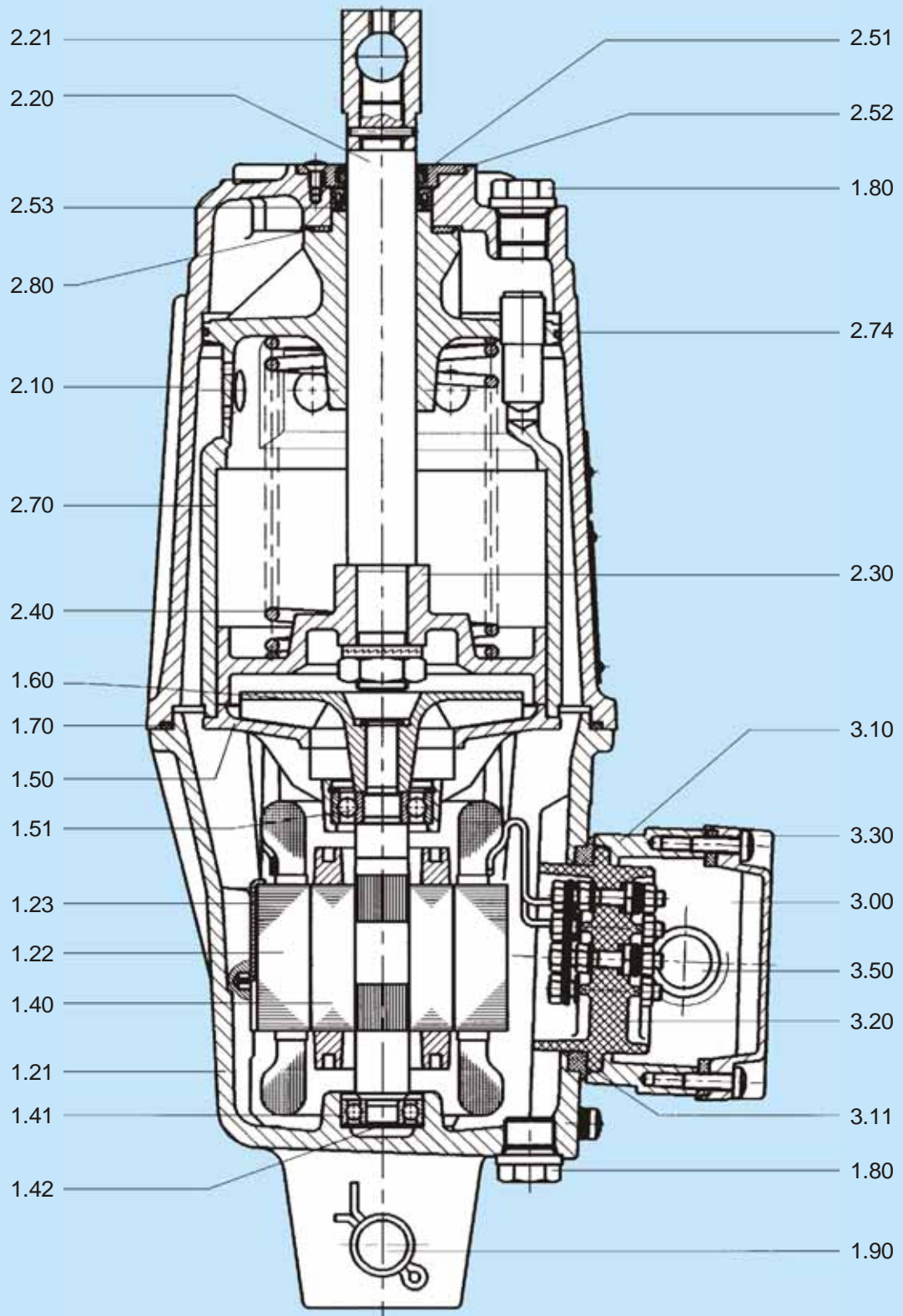

Design and Function

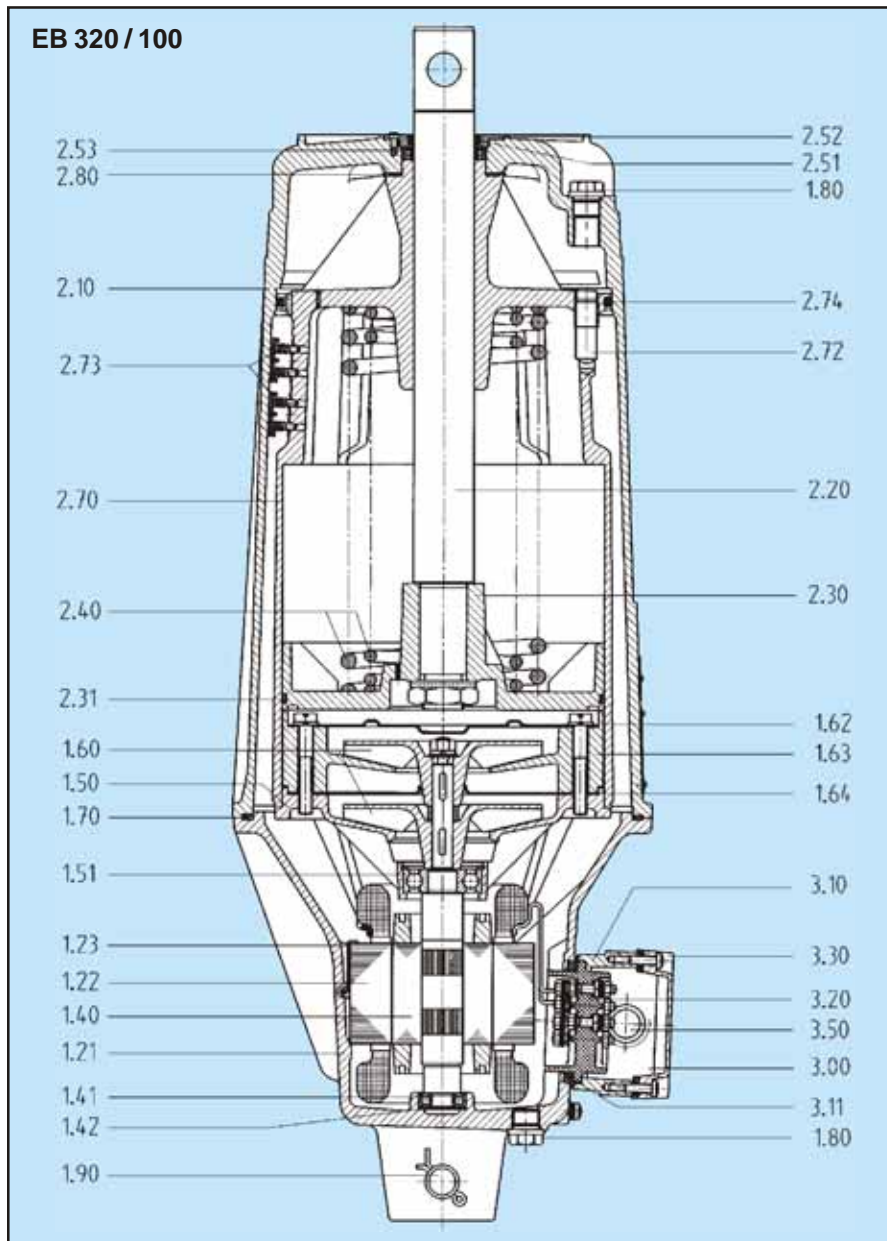

The motor-driven blade wheel generates a hydraulic pressure in the space beneath the piston. Consequently, a hydraulic force will act on the piston surface. This force is dependent on the hydraulic pressure and the size of the piston surface. However, the hydraulic force is independent of the position of the piston. Under the influence of the hydraulic force, the piston moves up and down and delivers the hydraulic fluid

through the bypass duct to the inlet opening of the blade wheel. When the motor is switched off, the piston is returned into its home position under the influence of the external load or the built-in pull-back spring. During this return motion, the hydraulic fluid under the piston is forced back through the blade wheel, the inlet opening and the bypass duct of the casing into the cylinder space above the piston.

Pull-back spring C

If a pull-back spring is provided between the piston and the bottom of the guide cylinder, then the hydraulic force is opposed by the spring force. Consequently, only the difference between these two forces is available as actuating power.

Adjusting spring R/Attenuation spring R

The adjusting spring R/attenuation spring R which is mainly provided in Elhy devices used as brake magnets ensures that during braking the braking force steadily increases from the moment of contact of the brake shoes till the value for stopping is reached, i.e. very smooth braking is facilitated. When the brake is released, the braking force steadily decreases from the maximum value down to zero.

Lifting, lowering and throttle valves H, S, D

If the Elhy device is furnished with one of these three valve types, it acts as a control point in the hydraulic circuit guiding the hydraulic flow in one and/or both directions. The type of valve used most frequently in Elhy devices applied as brake magnets is the lowering valve (S) which causes a delayed return movement of the piston and, consequently, compared to the switch-off moment, a delayed action of the brake. In actuating (lifting) direction of the piston, the valve will be opened due to the flow pressure in the hydraulic circuit, thus clearing a much larger inlet cross section in the partition wall between the cylinder space above the piston and the bypass duct allowing a quick actuating (lifting) movement. During the return movement, the valve is closed by the valve springs as well as by the flow pressure, and the hydraulic fluid can only flow through the opening which is cleared by the particular position of the regulating plug.

In the version using the lifting valve (H), the valve is arranged such that it acts opposite to the direction of the hydraulic flow and, consequently, also opposite to the piston stroke.

In the version using the throttle valve (D), the valve acts in both directions, i.e. the lowering as well as the lifting direction, so that a delay is caused in both stroke directions of the piston. The setting or pull-back times which are infinitely variable are set by means of the regulating plug.

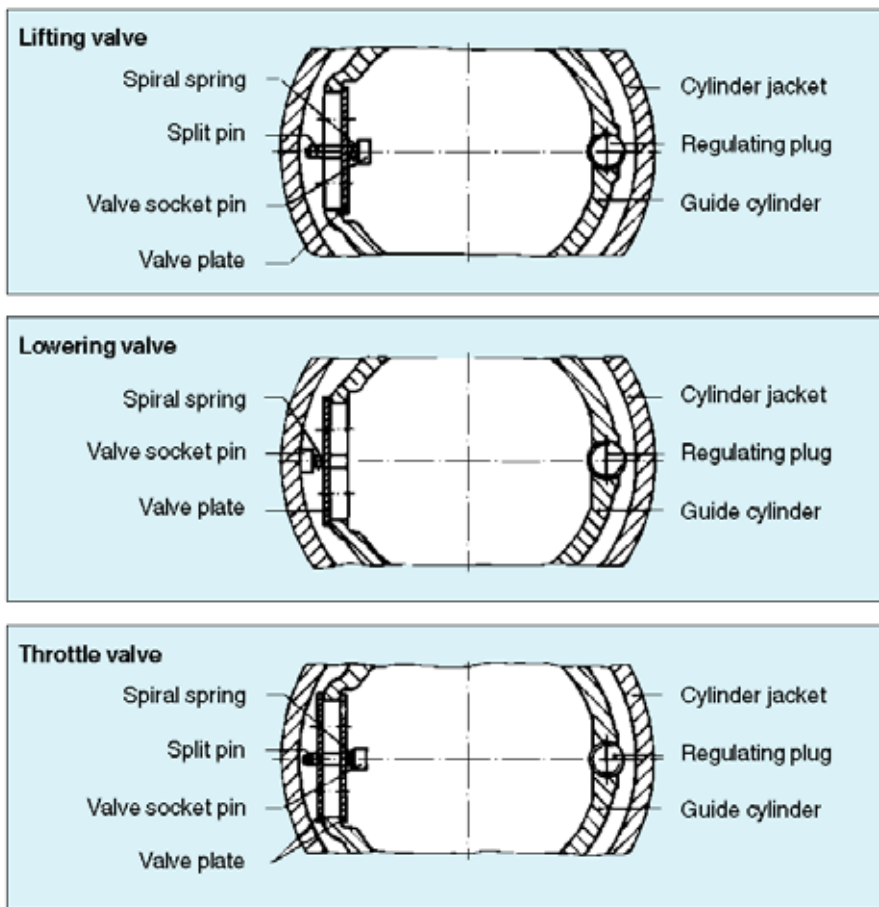

devices is determined by the heating up of components and hydraulic fluid. It is caused by losses occurring in the motor and in the pump system. Assuming an ambient temperature of +40°C, the admissible service temperatures will be below +100°C. Under conditions of high ambient temperatures (in tropical countries, installation near furnaces etc.), the type of duty shall be selected so that the admissible service temperature will not be exceeded. Otherwise the service life of the devices would be reduced. This should be considered during the design stage of the devices. Uninterrupted continuous operation of the Elhy devices leads to the highest permissible heating. In the case of intermittent duty, it should be observed that high switching rates as given in the rating table will be obtained when the drive motor is always started in the same direction of rotation. In the case of reversing operation, the possible number of switching operations is much lower.

Further extras

- Textile protective hood for the lifting rod,
- Position indicator with inductive or mechanical position sensor assembled external at the Elhy,
- Position indicator with magnetical-inductive sensor integrated in the Elhy,
- internal position sensor with analogue signal along the whole stroke with integrated transmitter for the indicated values (standard output signal 4 – 20 mA, three-wire connection),
- Plug and socket connection for terminal box,
- EB-thruster usable for higher ambient temperatures up to 70°C (Please enquire),
- Pedal control unit for soft braking

Controlled braking

Controlled braking is used to control the speed of three-phase motors independent of the load down to low speeds, e.g. in hoisting gears of assembly cranes. For this type of application, special Elhy devices are offered which should be selected in accordance with the customer's particular requirements

Service features

The actuating movement of the Elhy device is caused by a hydraulic force while the return movement is obtained under the influence of an external force (load). In devices with built-in pull-back spring, the return movement is brought about by this spring. In addition to overcoming the load, the hydraulic force must also overcome the kinetic resistances. Lifting is very smooth, because during motor start-up (lasting 0.1 to 0.15 sec.) the lifting power increases from zero as a function of the speed. Subsequently, the lifting speed is constant, even under conditions of spring loading.

Moreover, the return movement does also not commence immediately after the motor is disconnected, but approx 0.2 to 0.3 sec later. After an accelerated transition period, this motion is almost uniform, even in the case of spring loading. Just any position of the piston may be selected as home and end position. When used as a brake magnet, this feature means a great advantage with a view to brake lining wear. In the latter case, the first third of the stroke should be selected as home position when using new brake linings.

Types of duty

Elhy devices are mainly used in intermittent duty (S3). However, there are also types of application, requiring the devices to be permanently connected over extended periods of time (S1), such as travelling gear brakes which must be kept in the released position. The intermittent duty is determined by the percentage duty cycle (ED%) and frequency of operating cycles (c/h) The stress limit of the Elhy

Electrical Versions

The Elhy devices are equipped with a three-phase asynchronous squirrel-cage motor. Use of single-phase alternating current is possible in connection with a capacitor, however, the service parameters of the device will change in such a case. The same applies to operation in connection with a frequency converter. The terminal board will be supplied with three terminal clamps (U, V, W) or, on request, with six terminal clamps for windings which cannot be clamped (such as star-delta connections). After removing the four mounting screws, the frame of the terminal box can be turned through 90° each time.

Type of enclosure

In general, the casing of the Elhy device is completely tight, consequently all built in units including the motor are protected from any adverse environmental effects. Only the terminal box is subject to evaluation of the protective system. The terminal box is made in type of enclosure IP 56. The conduit hub Pg 21 is used for cable entry (11 to 20 mm diameter of feed line) and is made to the same type of enclosure.

Versions

To satisfy various requirements of application and environmental conditions, different types and versions are available. An overview over these versions is given in the table below. All sorts of combinations are possible.

Explanations to Table 'Ratings'

The service parameters given in the Table are applicable to 380 V/50 Hz and a transformer oil filling TRF-HX at +20°C.

- 1) The rated stroke is the largest possible piston stroke of a particular design. For practical use, the size of stroke can be freely selected within these limits, i.e. for any home and end positions.
- 2) The rated regulating power is the force which is available at the lifting rod in extending direction.
- 3) The rated resetting force is the minimum force in the rated operating point in case of a device equipped with a pull-back spring.
- 4) The service point is at the end of the first third of the rated stroke.

5) Power and current consumption data refer to an operating temperature of +20°C. At lower temperatures, these values may increase.

6) In general, all devices will be supplied with hydraulic fluid filling.

7) Setting and resetting times are applicable to weight loading or loading with the pull-back spring for devices without valves in vertical or horizontal service position. Maximum admissible deviations are +10%. The switching rate indicated refers to the thermal capacity. At rated load and utilization of the entire stroke, in some cases lower than specified switching rates may occur in some cases.

8) When pull-back spring C250/C2500 or C320/C3200 is installed, the stroke is limited to 60 mm.

Note:

All devices are available for types of duty S1 and S3 up to 2000 c/h and a cyclic duration factor of max. 100% for all three-phase voltages from 200 V to 690 V for 50 or 60 Hz.

All sealing materials used are free from asbestos!

Versions

	Standard version	Tropicalized version	Low-temperature version	Version for higher ambient temperature	Marine version	Explosion-version
Symbol		T	F	ZW, W ^{*)}	M ^{***)}	EExe ^{****)}
lowest admissible ambient temperature	-25°C	-25°C	(-50°C) ^{*)} -40°C	-10°C	-25°C	-20°C
highest admissible ambient temperature	+40°C	+45°C	+40°C	+50°C +60°C +70°C	+45°C	+40°C
Hydraul. fluid	Transformer oil	Transformer oil	Silicone	Transformer oil	Transformer oil	Transformer oil
Protection against corrosion	1-fold coating	3-fold coating	3-fold coating	3-fold coating	3-fold coating	3-fold coating

*) Heating during standstill via motor winding recommended

**) With reduced max. permissible mode of operating (not S1, S3 with max. 240 c/h, duration of switch on agreed with EMG-ELTMA)

***) Marine version in accordance with regulations Germanic Lloyd or of DSRK

****) Elhy devices in explosion-proof design, type of protection "d", enclosure resistant to pressure EExd/II BT 4 in compliance with European Standards EN 50014, 50018, 50019 are designed and manufactured as special series, compare Catalogue EExd.

Ratings

Standard series

Size	Type EB	Rated stroke 1) [mm]	Rated actuating force 2) [N]	Spring version	Rated resetting force 3) at rated operating point 4) [N]	Admissible deviation [+N]	Power consumption 5) kW	Current input 5) A	Volume of operating fluid l	Weight with hydraulic fluid 6) kg	Setting time 7) s	Resetting time 7) s
0	12/50	50	220	C 12	120	8	0.16	0.4	2.6	9.3	0.42	0.38
				C 18	180	11						
				C 22	220	11						
1	20/50	50	300	C 12	120	15	0.14	0.3	1.8	9.6	0.40	0.45
				C 20	200	24						
2	50/50	50	500	C 18	180	22	0.20	0.4	2.6	13.1	0.40	0.45
				C 32	320	39						
				C 50	500	61						
	50/100	100	500	C 18	130	20	0.20	0.4	3.2	14.5	0.75	0.70
				C 32	290	50						
				C 50	420	70						
3	80/60	60	800	C 45	450	54	0.26	0.5	4.3	19.0	0.40	0.45
				C 80	800	80						
				C 80	800	80						
	80/160	160	800	C 45	300	50	0.26	0.5	6.0	23.0	1.00	0.90
				C 80	520	75						
				C 80	520	75						
	125/60	60	1250	C 45	450	54	0.38	0.6	4.3	20.6	0.55	0.38
				C 80	800	80						
				C 125	1250	134						
	125/160	160	1250	C 45	300	50	0.38	0.6	6.0	24.2	1.35	0.80
				C 80	520	75						
				C 125	820	125						
	150/60	60	1500	C 45	450	54	0.40	0.7	4.3	20.6	0.65	0.35
				C 80	800	80						
				C 125	1250	134						
	150/160	160	1500	C 45	300	50	0.40	0.7	6.0	24.2	1.20	0.75
				C 80	520	75						
				C 125	820	125						
4	250/60	60	2500	C 70	700	70	0.50	0.7	9.0	32.8	0.60	0.40
				C 130	1300	130						
				C 200	2000	200						
	250/160	160	2500	C 70	510	60	0.50	0.7	12.2	39.5	1.50	0.85
				C 130	850	130						
				C 200	1360	190						
	320/100	100	3200	C 70	580	60	0.55	0.9	10.6	39.5	1.00	0.60
				C 250 ⁸⁾	2300	230						
				C 320 ⁸⁾	2950	295						
5	630/120	120	6300	C 70	580	60	0.80	1.6	10.6	43.5	1.20	0.35
				C 250 ⁸⁾	2300	230						
				C 320 ⁸⁾	2950	295						

Series EB acc. to DIN 15430

Size	Type EB	Rated stroke 1) [mm]	Rated actuating force 2) [N]	Spring version	Rated resetting force 3) at rated operating point 4) [N]	Admissible deviation [+N]	Power consumption 5) kW	Current input 5) A	Volume of operating fluid l	Weight with hydraulic fluid 6) kg	Setting time 7) s	Resetting time 7) s
0	120-40	40	120	C 6	60	9	0.13	0.4	1.2	7.5	0.21	0.25
	C 12			120	16							
	220-50	50	220	C 120	120	8	0.16	0.4	2.6	9.3	0.42	0.38
				C 180	180	11						
				C 220	220	11						
1	300-50	50	300	C 120	120	15	0.14	0.3	1.8	9.6	0.45	0.33
				C 200	200	24						
				C 270	270	24						
2	500-60	60	500	C 180	180	22	0.20	0.4	2.6	13.1	0.42	0.33
				C 320	320	39						
				C 500	500	61						
	500-120	120	500	C 180	132	16	0.20	0.4	3.5	14.8	0.78	0.55
				C 320	300	36						
				C 500	432	52						
3	800-60	60	800	C 450	450	54	0.26	0.5	4.3	19.0	0.37	0.40
				C 800	800	80						
	800-120	120	800	C 450	300	50	0.38	0.5	6.0	23.0	0.70	0.55
				C 800	520	75						
	1250-60	60	1250	C 450	450	54	0.38	0.6	4.3	20.6	0.48	0.29
				C 800	800	80						
				C 1250	1250	134						
	1250-120	120	1250	C 450	300	50	0.38	0.6	6.0	24.2	0.95	0.55
				C 800	520	75						
				C 1250	820	125						
4	2000-60	60	2000	C 700	700	70	0.50	0.7	9.0	32.8	0.55	0.33
				C 1300	1300	130						
				C 2000	2000	200						
	2000-120	120	2000	C 700	510	60	0.50	0.7	9.0	32.8	1.10	0.55
				C 1300	850	130						
				C 2000	1360	190						
	3000-60	60	3000	C 700	700	70	0.55	0.9	10.1	39.0	0.60	0.38
				C 2500 ⁸⁾	2300	230						
				C 3200 ⁸⁾	2950	300						
	3000-120	120	3000				0.55	0.9	10.1	39.0	1.10	0.62
5	6300-120	120	6300	C 700	700	70	0.80	1.6	10.6	43.5	1.20	0.30
				C 2500 ⁸⁾	2300	230						
				C 3200 ⁸⁾	2950	300						

Spezial versions following DIN 15430

Size	Type EB	Rated stroke 1) [mm]	Rated actuating force 2) [N]	Spring version	Rated resetting force 3) at rated operating point 4) [N]	Admissible deviation [+N]	Power consumption 5) kW	Current input 5) A	Volume of operating fluid l	Weight with hydraulic fluid 6) kg	Setting time 7) s	Resetting time 7) s
2	320-50	50	320	C 180	180	22	0.6	0.3	2.6	13.0	0.32	0.32
				C 320	320	39						
	320-100	100	320	C 180	132	16	0.16	0.3	3.5	14.7	0.55	0.48
				C 320	300	36						
	500-50	50	500	C 180	180	22	0.20	0.4	2.6	13.1	0.36	0.30
				C 320	320	39						
				C 500	500	61						
	500-100	100	500	C 180	132	16	0.20	0.4	3.5	14.8	0.65	0.50
C 320				300	36							
C 500				432	52							
3	800-160	160	800	C 450	300	50	0.26	0.5	6.0	23.0	0.90	0.70
				C 800	520	75						
	1250-160	160	1250	C 450	300	50	0.38	0.6	6.0	24.2	1.25	0.65
				C 800	520	75						
				C 1250	820	125						
	1500-60	60	1500	C 450	450	54	0.40	0.7	4.3	20.6	0.65	0.28
				C 800	800	80						
				C 1250	1250	134						
1500-160	160	1500	C 450	300	50	0.40	0.7	6.0	24.2	1.65	0.60	
			C 800	520	75							
			C 1250	820	125							
4	2500-60	60	2500	C 700	700	70	0.50	0.7	9.0	32.8	0.60	0.30
				C 1300	1300	130						
				C 2000	2000	200						
	2500-160	160	2500	C 700	510	60	0.50	0.7	12.0	39.5	1.45	0.60
				C 1300	850	130						
				C 2000	1360	190						
	3200-100	100	3200	C 700	580	60	0.55	0.9	10.1	39.0	1.00	0.55
				C 2500 ⁸⁾	2300	230						
C 3200 ⁸⁾				2950	295							

Assembly Dimensions

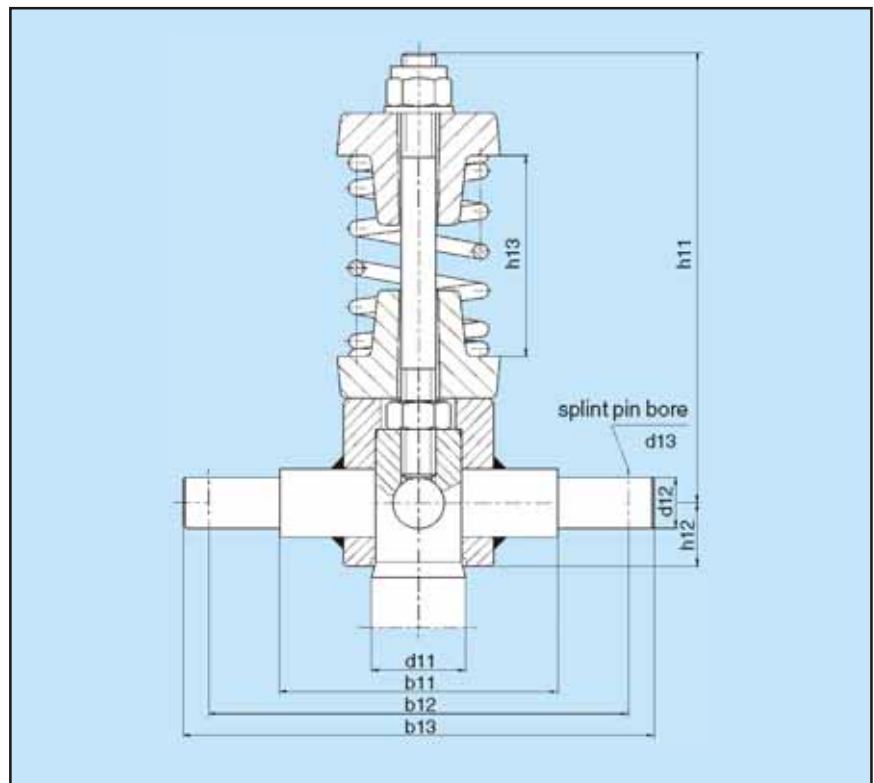
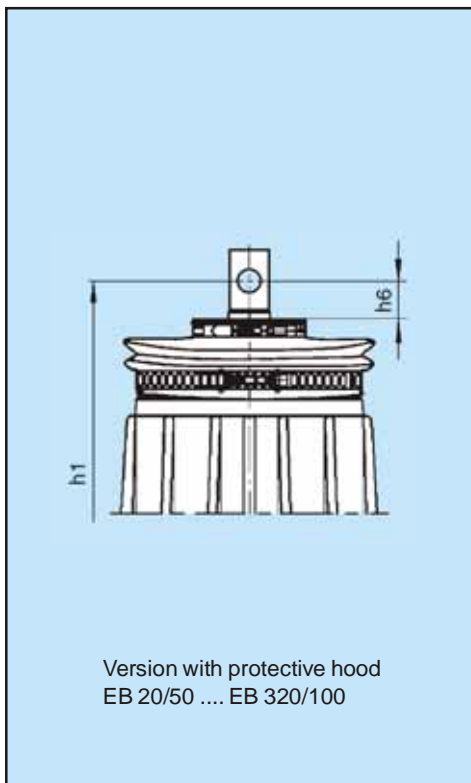
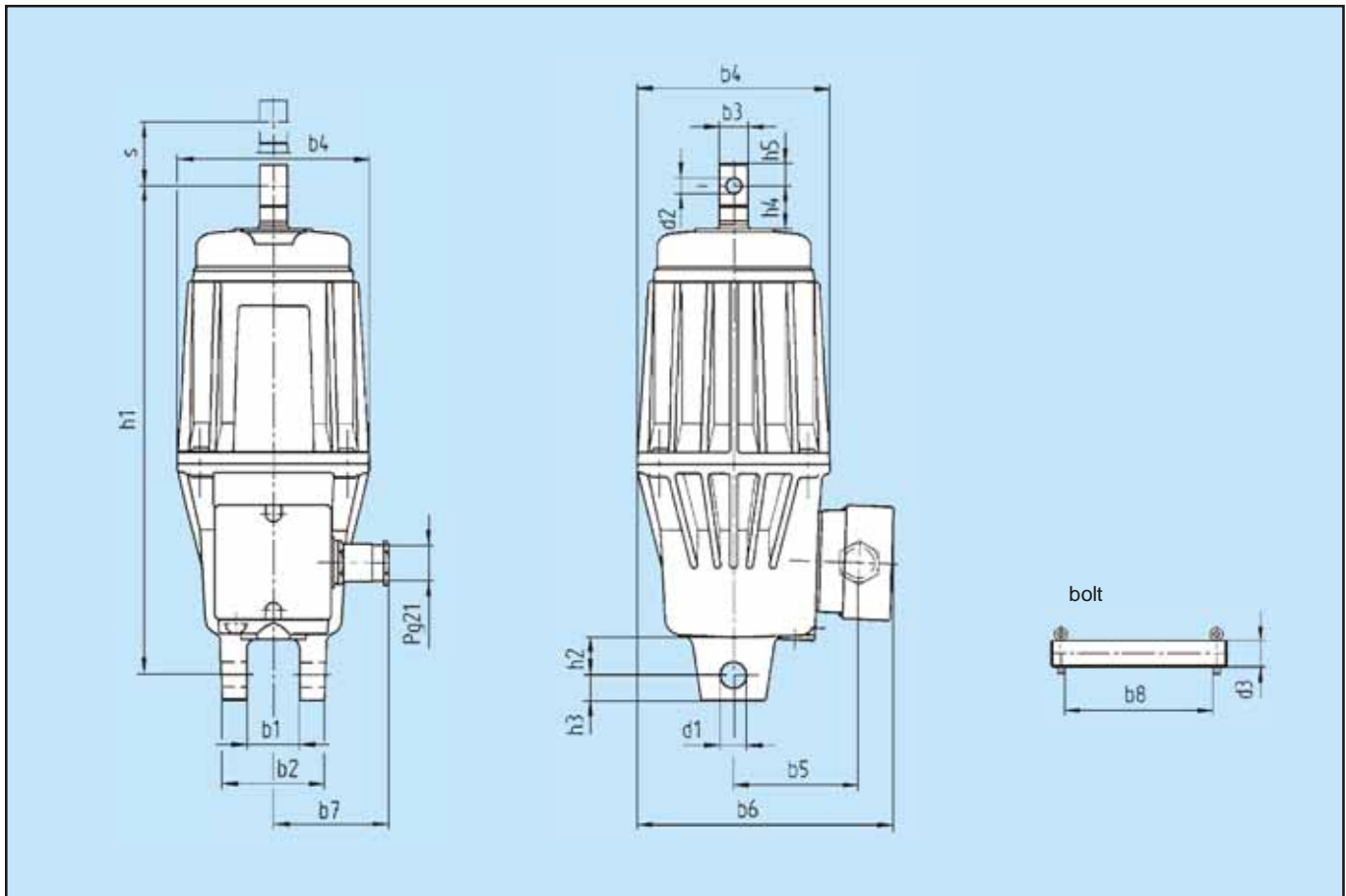

size	type	s	b ₁ +2	b ₂ +1	b ₃ e8	b ₄	b ₅	b ₆	b ₇	d ₁ +0.1	d ₂ F9	h ₁ ±1	h ₂	h ₃ +1	h ₄ ±1	h ₅	d ₃ h11	b ₈ +1	h ₆
Standard series EB																			
0	EB 12 -1 ¹⁾	50	–	–	20	162	81	236	100	16.1	12	272	–	–	23	17	–	–	–
	EB 12 -2 ²⁾	50	40	80	20	162	81	236	100	16.1	12	286	20	16	23	17	16	104	–
	EB 12 -3 ³⁾	50	40	80	20	162	81	236	100	16.1	12	314	38	16	23	17	16	104	–
1	EB 20	50	40	80	21.5	150	97	200	100	20.2	12	380	30	20	30	17	20	114	23
2	EB 50	50	40	90	21.5	180	102	220	100	20.2	12	400	30	20	32	17	20	114	25
	EB 50	100	40	90	21.5	180	102	220	100	20.2	12	452	30	20	32	17	20	114	25
3	EB 80, 125, 150	60	40	90	27.5	208	102	232	100	20.2	16	458	30	25	36	21	20	114	27
	EB 80, 125, 150	160	40	90	27.5	208	102	232	100	20.2	16	573	30	25	36	21	20	114	27
4	EB 250	60	40	90	35.5	250	110	265	100	20.2	20	549	30	25	36	25	20	114	28
	EB 250	160	40	90	35.5	250	110	265	100	20.2	20	660	30	25	36	25	20	114	28
	EB 320	100	40	90	35.5	250	110	265	100	20.2	20	660	30	25	36	25	20	114	28
5	EB 630	120	40	90	35.5	250	110	265	100	20.2	20	660	30	25	36	25	20	114	28
size	type					b ₁₁ ±0.5	b ₁₂ +0.5	b ₁₃		d ₁₁ ±0.1	d ₁₂ e8		d ₁₃	h ₁₁	h ₁₂	h ₁₃ –1			
Adjusting spring for standard series EB																			
0	EB 12/50					65	98	110		20	12		5	106	15				47.5
1.2	EB 20/50, 50/50, 50/100					65	98	110		21.7	12		5	106	26				47.5
3	EB 80/60,80/160, 125/60, 125/160 EB 150/60, 150/160					65	98	110		21.7	16		5	140	27				65
4	EB 250/60, 250/160, 320/100					70	105	120		35.7	20		5	189	30				102

1) flange mounting version

2) thruster with cast-on eyes

3) thruster with bolted bottom plate

dimensions in mm

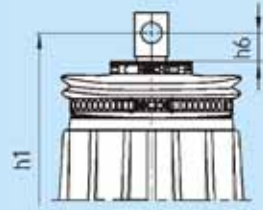
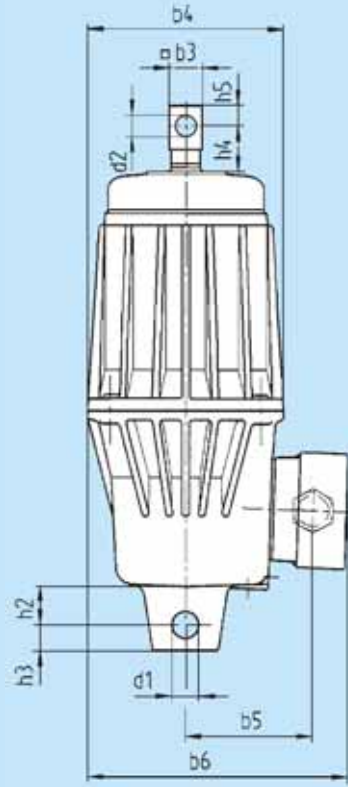
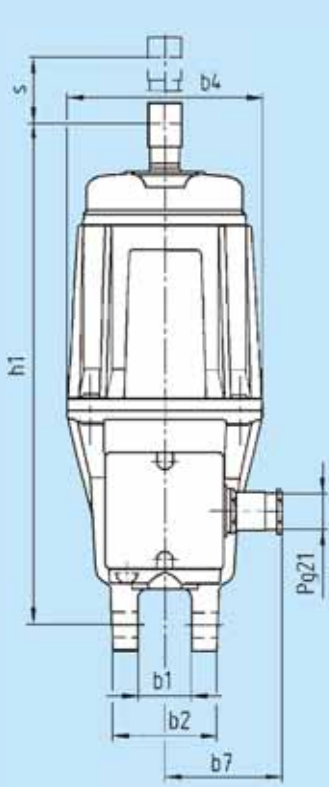

Version with protective hood
EB 300 – 50 EB 3200/120

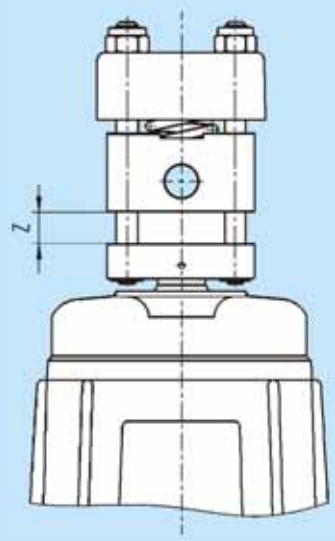
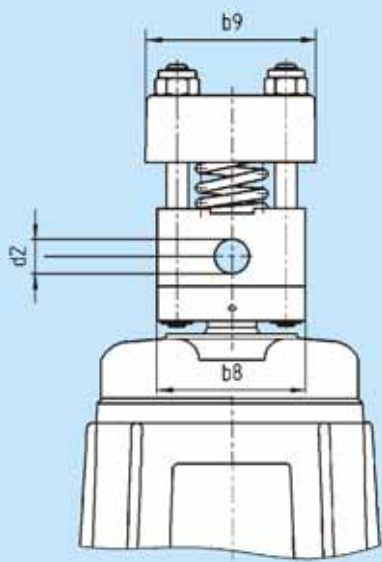
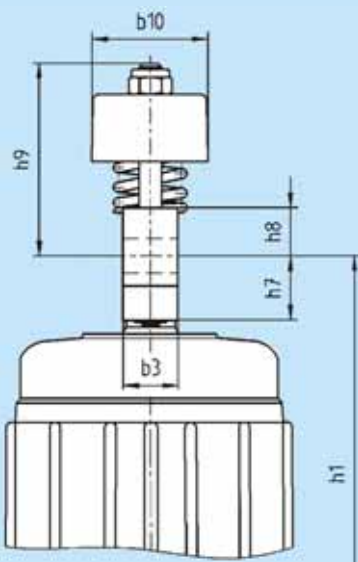
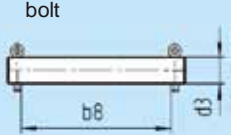

size	type	s	b ₁ +2	b ₂ +1	 b ₃ -0.1	b ₄	b ₅	b ₆	b ₇	d ₁ +0.1	d ₂ F9	h ₁ ±0.1	h ₂	h ₃ +1	h ₄ ±0.1	h ₅	d ₃ h11	b ₈ +1	h ₆	
Series acc. to DIN 15430																				
0	EB 120 -2 ²⁾	40	25	45	20	110	100	178	55	12.1	12	265	12	14	20	10	-	-	-	
	EB 120 -3 ³⁾	40	40	60	20	110	100	178	55	16.1	12	286	16	23	20	10	-	-	-	
	EB 220 -1 ¹⁾	50	-	-	20	162	81	236	100	16.1	12	272	-	-	26	15	-	-	-	
	EB 220 -2 ²⁾	50	40	80	20	162	81	236	100	16.1	12	286	20	16	26	15	16	104	-	
	EB 220 -3 ³⁾	50	40	80	20	162	81	236	100	16.1	12	314	38	16	26	15	16	104	-	
1	EB 300	50	40	80	25	150	97	200	100	16.1	16	370	18	16	32	15	16	104	21	
2	EB 500	60	60	120	30	180	102	220	100	20.1	20	435	30	20	67	18	20	144	46	
	EB 500	120	60	120	30	180	102	220	100	20.1	20	515	30	20	95	18	20	144	59	
3	EB 800	60	60	120	30	208	102	232	100	20.1	20	458	23	22	42	18	20	144	24	
	EB 800	120	60	120	30	208	102	232	100	20.1	20	530	23	22	39	18	20	144	24	
	EB 1250	60	40	90	40	208	102	232	100	25.1	25	645	30	25	108	25	25	114	88	
	EB 1250	120	40	90	40	208	102	232	100	25.1	25	705	30	25	168	25	25	114	78	
4	EB 2000	60	40	90	40	250	110	265	100	25.1	25	645	30	25	132	25	25	114	107	
	EB 2000	120	40	90	40	250	110	265	100	25.1	25	705	30	25	81	25	25	114	56	
	EB 3000	60	40	90	40	250	110	265	100	25.1	25	660	30	25	36	25	25	114	29	
	EB 3000	120	40	90	40	250	110	265	100	25.1	25	705	30	25	81	25	25	114	61	
5	EB 6300	120	40	90	40	250	110	265	100	25.1	25	705	30	25	83	25	25	114	63	
Special versions following DIN 15430																				
2	EB 320	50	40	80	25	180	102	220	100	16.1	16	385	18	16	30	18	16	104	46	
	EB 320	100	40	80	25	180	102	220	100	16.1	16	493	18	16	85	18	16	104	39	
	EB 500	50	60	120	30	180	102	220	100	20.1	20	435	30	20	65	18	20	144	46	
	EB 500	100	60	120	30	180	102	220	100	20.1	20	515	30	20	95	18	20	144	59	
3	EB 800	160	60	120	30	208	102	232	100	20.1	20	573	23	22	42	18	20	144	29	
	EB 1250	160	40	90	40	208	102	232	100	25.1	25	705	30	25	168	25	25	114	78	
	EB 1500	60	40	90	40	208	102	232	100	25.1	25	645	30	25	108	25	25	114	88	
	EB 1500	160	40	90	40	208	102	232	100	25.1	25	705	30	25	168	25	25	114	88	
4	EB 2500	60	40	90	40	250	110	265	100	25.1	25	645	30	25	152	25	25	114	107	
	EB 2500	160	40	90	40	250	110	265	100	25.1	25	705	30	25	81	25	25	114	56	
	EB 3200	100	40	90	40	250	110	265	100	25.1	25	660	30	25	36	25	25	114	29	
size	type																			
		b ₃	b ₈	b ₉	b ₁₀	d ₂ F9	h ₇	h ₈	h ₉	Z										
Attenuation spring (series acc. to DIN 15430 / special versions following to DIN 15430)																				
0	EB 220 - 50	20	68	78	52	12	36	20	89	15										
1	EB 300 - 50	25	68	78	52	16	30	20	75	15										
2.3	EB 320 - 50, 320 - 100																			
	EB 500 - 50, 500 - 100																			
	EB 500 - 60, 500 - 120	30	68	78	52	20 ⁴⁾	36 ⁵⁾	20	100	20 ³⁾										
	EB 800 - 60, 800 - 120, 800 - 160																			
3.4	EB 1250 - 60, 1250 - 120, 1250 - 160																			
	EB 1500 - 60, 1500 - 160																			
	EB 2000 - 60, 2000 - 120																			
	EB 2500 - 60, 2500 - 160	40	110	116	76	25	38	35	175	20										
	EB 3000 - 60, 3000 - 120																			
	EB 3200 - 100																			

1) flange mounting version

2) thruster with cast-on eyes

3) thruster with bolted bottom plate

4) EB 320 - 50 h₇ = 30 mm, d₂ = 16 mm

5) EB 320 - 50 und 500 - 50 z = 15 mm

dimensions in mm

Design, Engineering and Putting into Operation

Installation

The Elhy device is connected to the unit to be actuated by means of two bolts. These bolts should fit well, however, must not impair the slewing capacity of the device to avoid any jamming which might affect the motion of the lifting rod or even cause damage to its support, guide and packing.

Service positions

It is possible to use the Elhy devices in vertical, horizontal (lifting rod in horizontal position $\pm 30^\circ$) or inverted position. In the vertical position, installation and operation are easiest. In the horizontal and inverted positions, the device may be installed so that the terminal box will be located at the side, provided the symbol 'II' was added after the type designation in the order. If in the horizontal service position space considerations require to mount the terminal box either on top or on the bottom, a modification of the device is required and has to be carried out by a specialist. When ordering this version, the symbol 'I' must be added after the type designation. If Elhy devices are to be used in an inverted position (lifting rod vertically downwards $\pm 60^\circ$), Consultation with the manufacturer is necessary.

Connecting the motor

To ensure unimpaired slewability, the motor shall be connected via a free connecting lead. Since motor operation is independent of the direction of rotation, the three feed lines can be connected to terminals U, V, W in optional sequence.

Filling-in the hydraulic fluid

The Elhy devices are delivered in filled state. When filling the devices, e.g. after maintenance and repair work, the following notes shall be observed:

Insulation oil shall be used exclusively. Best suited for normal operating conditions is transformer oil with viscosity properties of

approx: 20 mm²/sec at +20°C

approx: 1000 mm²/sec at -30°C

such as Addinol TRF-HX Transformer oil.

For temperatures colder than -25°C use should be made of silicone oil with viscosity properties of

approx: 50 mm² /sec at +20°C

approx: 500 mm² /sec at -50°C

200 Fluid 10 cs from Dow corning

These mediums are well tested with regard to lifting rod sealing. The hydraulic fluid must not contain any water droplets. The devices should be filled in vertical position. To this end, the regulating plug shall be removed and the fluid filled in through the inlet opening. During filling, the piston should be completely moved in. In the vertical position, the Elhy device is correctly filled when the hydraulic fluid level reaches the lower edge of the inlet opening. After completed filling it is recommended to move the piston several times by hand to force any entrapped air to the top. For devices equipped with a pull-back spring, this can be accomplished electrically.

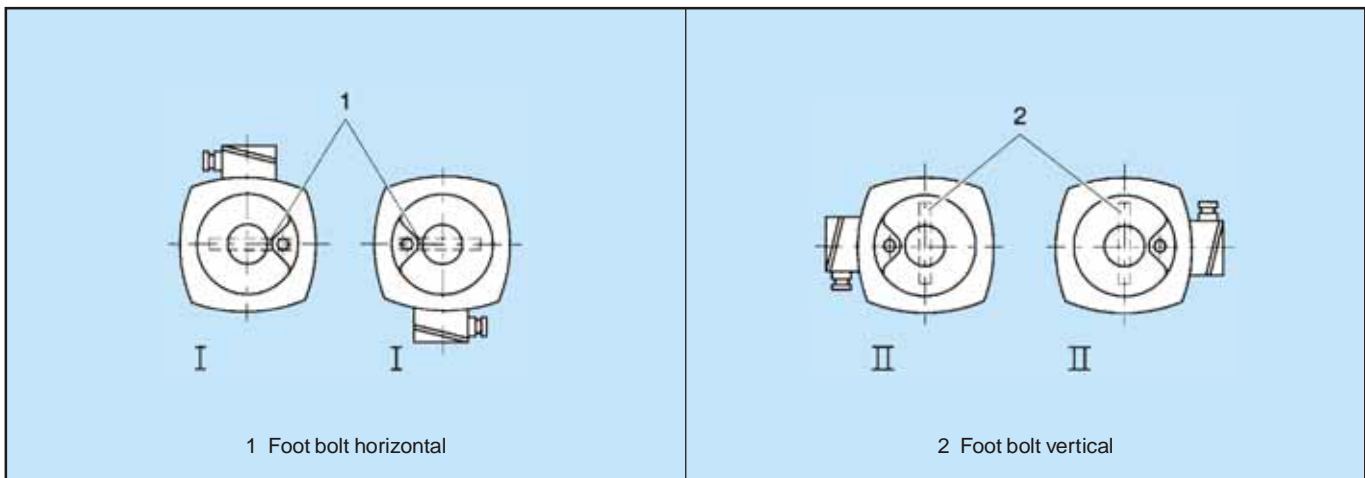

Putting into Operation

When putting the device into operation make sure that the lifting rod is not exposed to any shearing forces. It is necessary, above all, to ensure that the motion of the elements to be driven will take place at the same level as the slewing motion of the device around the fastening bolts. If the device does not work properly, make sure first of all that the requirements mentioned above including the filling are satisfied. In addition make sure that the lifting rod is neither damaged nor dirty, e.g. by paint residues due to subsequent painting of the equipment. This might damage the lifting rod packing. The lifting rod is resistant to external corroding effects. However, in very dirty or humid environments (severe impact of dirt, water and the like) it is recommended to protect both lifting rod and lifting rod packing by a protective guard.



LAUBAG open-cast mine at Welzow-Süd, 3 Es 3150 with 582 ELHY units

Type Designation

Standard Series

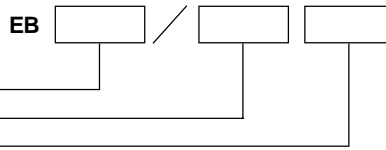

Rated actuating force in kgf _____

Rated stroke in mm _____

Versions _____

- C = Pull-back spring (indicating spring power in kgf)
- R = Adjusting spring
- B = Controlled braking
- H, S, D = Type of valve
- Z = Protective guard
- Li, Lm, Lk = Position indicator
- T, F, M, EExe = Tropical, Low-temperature, Marine, Explosion-proof versions

Examples of Type Designations

EB 50/100

Standard series EB
 Rated actuating force 50 kgf (500 N)
 Rated stroke 100 mm

EB 1250-60 C800 R

Series EB acc. to DIN 15430
 Rated actuating force 1250 N
 Rated stroke 60 mm
 Resetting force 800 N
 Attenuation spring R

Series in compliance with DIN 15430 or special versions following DIN 15430

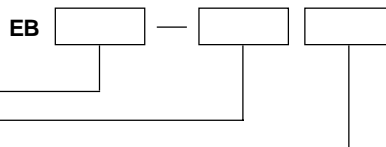

Rated actuating force in N _____

Rated stroke in mm _____

Versions _____

- C = Pull-back spring (indicating spring power in N)
- R = Attenuation spring
- B = Controlled braking
- H, S, D = Type of valve
- Z = Protective guard
- Li, Lm, Lk = Position indicator
- T, F, M, EExe = Tropical, Low-temperature, Marine, Explosion-proof versions

Note:

The difference between the Standard Series and the DIN Series or special versions following DIN 15430 is clear from either the oblique stroke or the hyphen between the data specifying rated actuating force and rated stroke, respectively

How to order Elhy Devices

To ensure correct selection of the devices, the following information is required when ordering. This page may be used for ordering and can be enclosed with the official

order form. If you want to order a stand-by device, please indicate the device No. of the unit which is already in your possession.

<p>1. Application (e.g. as brake magnet, for flap actuation etc.) _____ _____ _____</p>	<p>8. Service position of the Elhy device: <input type="checkbox"/> Vertical with lifting rod vertically upwards <input type="checkbox"/> Horizontal with lifting rod in horizontal position (±30°) <input type="checkbox"/> Inverted with lifting rod vertically downwards</p>	<p>10. Monitoring device (Layer indication) <input type="checkbox"/> Inductive <input type="checkbox"/> Mechanical</p> <p>10.1 Monitoring function for: <input type="checkbox"/> Lifted position <input type="checkbox"/> Braking position <input type="checkbox"/> Wear control (Li only)</p> <p>10.2 Arrangement for one-sided installation of switching equipment (looking to the name plate) <input type="checkbox"/> switch on the left <input type="checkbox"/> switch on the right</p>
<p>2. Service voltage/Frequency <input type="checkbox"/> 220 V <input type="checkbox"/> 220/380 V <input type="checkbox"/> 50 Hz <input type="checkbox"/> 230 V <input type="checkbox"/> 230/400 V <input type="checkbox"/> 60 Hz <input type="checkbox"/> 380 V <input type="checkbox"/> 380/660 V <input type="checkbox"/> 400 V <input type="checkbox"/> 400/690 V <input type="checkbox"/> 660 V <input type="checkbox"/> 690 V <input type="text"/> V Special voltage</p>	<p>8.1 Position of the terminal box <input type="checkbox"/> top <input type="checkbox"/> bottom shifted: <input type="checkbox"/> L.H. 90° <input type="checkbox"/> R.H. 90°</p>	<p>11. Environmental conditions Ambient temperature minimum ____°C maximum ____°C <input type="checkbox"/> outdoor installation, unroofed <input type="checkbox"/> outdoor installation, roofed <input type="checkbox"/> indoor installation</p>
<p>3. Stroke required: mm</p> <p>4. Actuating (Lifting) force required: N</p> <p>5. Resetting force required: N</p> <p>6. Prolongation of actuating time: yes/no</p> <p>7. Prolongation of resetting time: yes/no</p>	<p>9. Type of duty <input type="checkbox"/> Continuous duty <input type="checkbox"/> Intermittent service S3 with: ___ switching operations per hour, same direction of rotation of Elhy motor, ___ percentage run time per hour <input type="checkbox"/> Intermittent service S3 with: ___ switching operations per hour, alternating direction of rotation of Elhy motor, ___ percentage run time per hour</p>	<p>12. Particular requirements on site (e.g. due to severe dirt, coal dust, ash, drifting sand, fertilizers, cement dust, aggressive media, sea water, explosion protection) _____ _____</p>
		<p>13. Assembly dimensions EB Standard Series EB Series in compliance with DIN 15430 EB Special versions following DIN 15430</p>



View of company premises

EMG-ELTMA Hebezeuge Oschersleben GmbH

Am Pfefferbach 20
D-39387 Oschersleben

Telefon: ++49 / 3949 / 928 500
 Telefax 1: ++49 / 3949 / 928 585
 Telefax 2: ++49 / 3949 / 928 513
 e-mail: info@emg-eltma.de
 http: www.emg-eltma.de

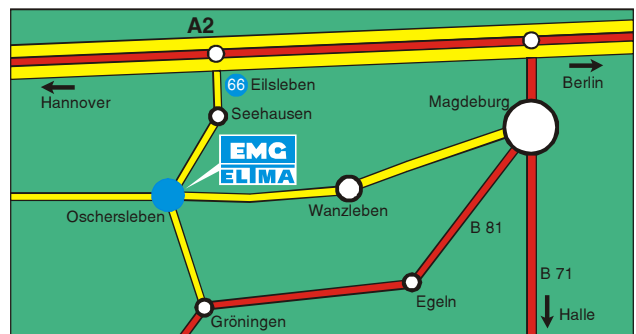

How to get to our company

Our quality is your security



Änderungen vorbehalten



EMG-ELTMA 11/00 englische Fassung /

