

Description:

- The FSB 75 FC brake is a Fail Safe Brake, Spring Applied, Hydraulic Released, braking force adjustable by variation of air gap and by variation of spring package.
- The FSB 75-FC brake is designed as a floating calliper.
FSB 75-FC brakes are suitable for horizontal and vertical brake discs under any angular displacement

Design Advantage:

- Compact and robust construction
- Fast response time, fast braking for maximum safety
- Stainless steel piston
- Sinter linings for high speed/high energy application
- Retraction springs ensure air gap between lining and disc, when brake is open
- Optimized lining pressure distribution by innovative force transmission
- Optimized isolation of lateral forces
- Minimized risk of leakage
- Suitable for low temperature application
- Long life time
- Easy maintenance

Application:

Stopping and / or Holding brake for Wind Power Generator

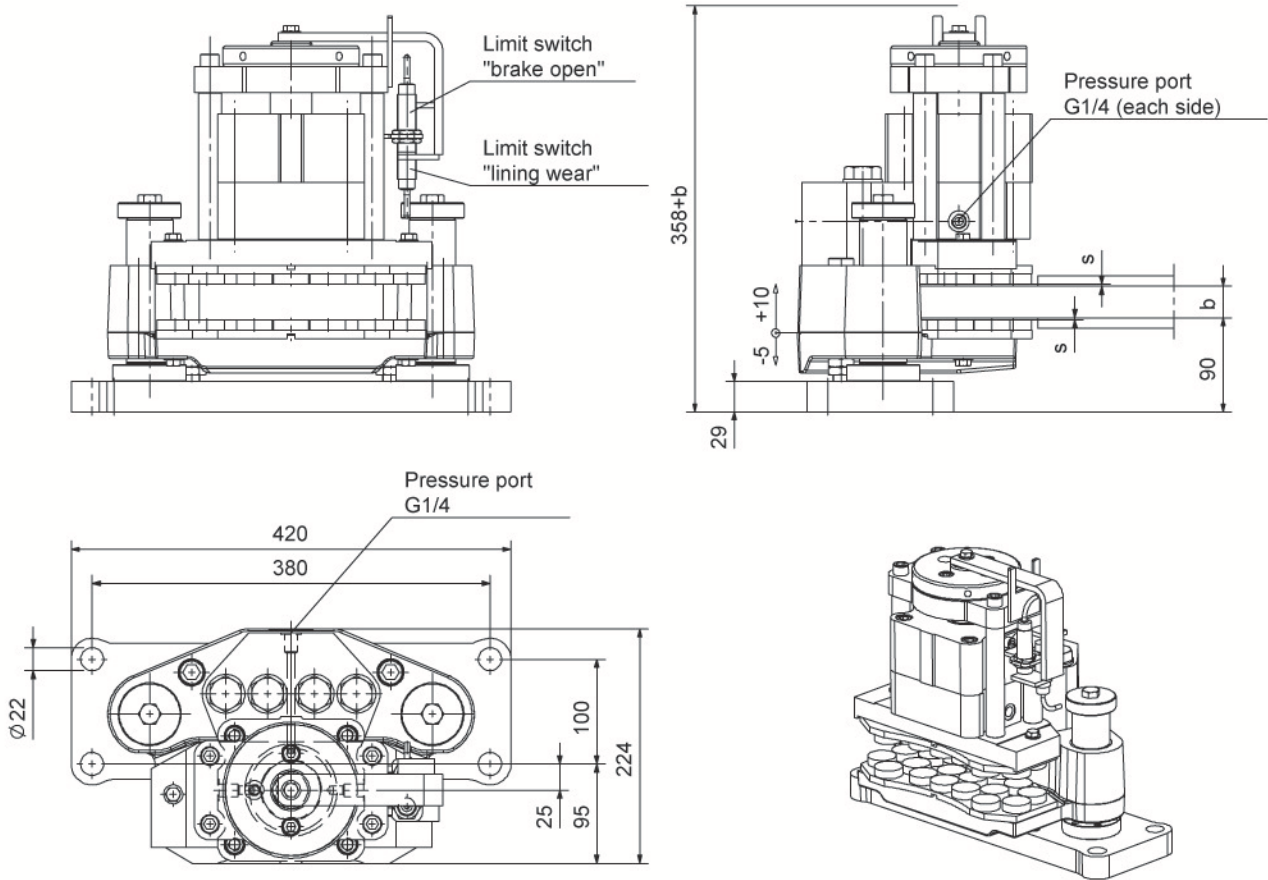

Piston area	A_p	50,3 cm ²
Oil volume per 1 mm stroke	V_{oil}	5,0 cm ³
Adjustable air gap (each side)	s	0,75 – 1,5 mm
Lining type		sinter
Lining surface	A_L	163 cm ²
Max. lining wear	s_L	8 mm
Nominal friction coefficient	μ	0,4
Disc thickness	b	20 - 40 mm
Minimum disc diameter	$\varnothing D_{min}$	500 mm
Maximum disc diameter	$\varnothing D_{max}$	4000 mm
Floating range on guidance pins	r	-5 / +10 mm
Temperature range (for lower temperatures please contact us)	T	-20°C to 70°C
Weight (complete)	m	85 kg

Mounting

$$Y = 90 + 10/-5$$

(for change of brake linings,
possible on both sides)

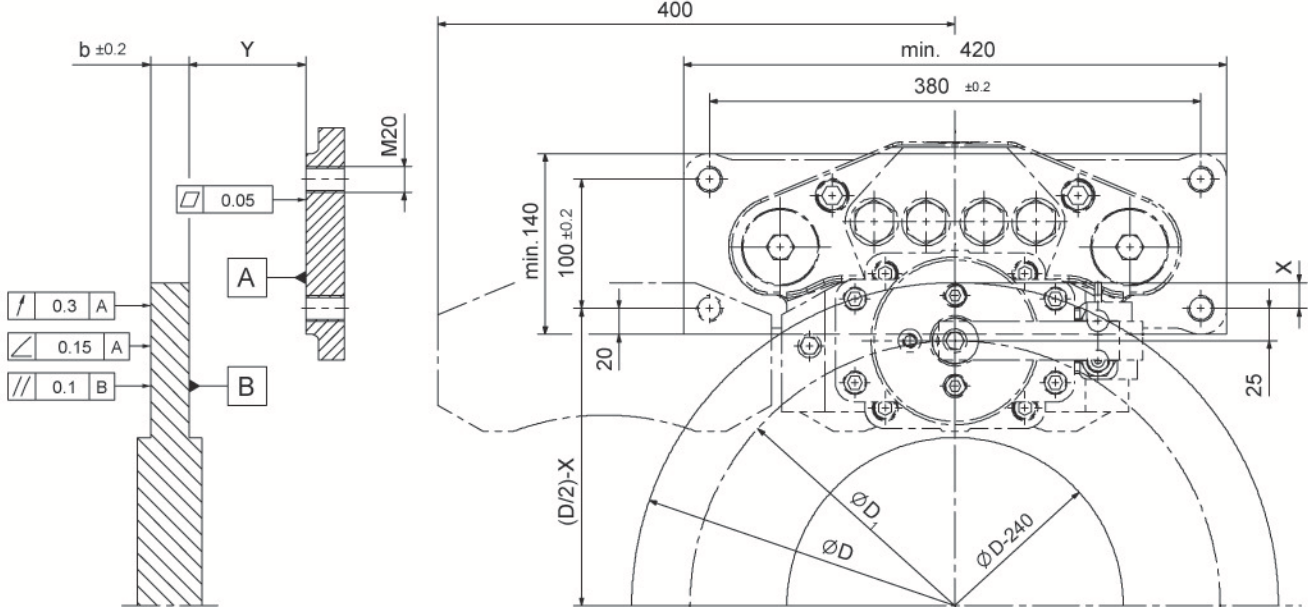

$\varnothing D$	$\varnothing D1$	X
$500 \leq \varnothing D < 1500$	$\varnothing D1 = \varnothing D - 90$	20
$1500 \leq \varnothing D < 1600$	$\varnothing D1 = \varnothing D - 86$	18
$1600 \leq \varnothing D < 2000$	$\varnothing D1 = \varnothing D - 80$	15
$2000 \leq \varnothing D < 4000$	$\varnothing D1 = \varnothing D - 70$	10

Calculation of Braking Torque

Clamping Force F_C	FSB 75-1 FC	FSB 75-2 FC	FSB 75-3 FC	FSB 75-4 FC	FSB 75-5 FC	FSB 75-6 FC
F_C (s = 0,75 mm)	18,1 kN	21,6 kN	24,6 kN	29,1 kN	42,8 kN	48,6 kN
F_C (s = 1,00 mm)	17,9 kN	20,7 kN	23,9 kN	27,6 kN	41,0 kN	47,3 kN
F_C (s = 1,25 mm)	17,7 kN	19,9 kN	23,1 kN	26,1 kN	39,1 kN	46,0 kN
F_C (s = 1,50 mm)	17,6 kN	19,0 kN	22,4 kN	24,6 kN	37,0 kN	44,4 kN
F_C (brake released)	21,0 kN	26,0 kN	30,0 kN	37,0 kN	56,0 kN	61,0 kN
Release pressure p	45 bar	55 bar	65 bar	80 bar	120 bar	135 bar
Max. operating pressure p_{max}	85 bar	85 bar	110 bar	110 bar	150 bar	175 bar

$$M_{Br} = F_{Br} \cdot \frac{D_1}{2} = 2 \cdot F_C \cdot \mu \cdot \frac{D_1}{2} = F_C \cdot \mu \cdot D_1$$