

When ordering please advice:
 - Order-no., e.g. for TE 160/220/50
 - power supply voltage of thruster
 - with or without autom. wear compensator
 - optional features such as limit switch manual release, drum, coupling, covering cap

Brake type	No.	Thruster unit	Mbr. (Nm) torque $\mu = 0,4$	A	B	C	H
TE 160/120/40	1	EB 120/40	45 - 125	575	110	73	395
TE 220/220/50	2	EB 220/50	55 - 230	610	162	100	400

The drum brake TE 160 offer a particularly usability for compact-drives, e. a. vertical mounting, travel drives. Our scope of supply is beneath the brake also mounting console for adapting gearbox and motor as well as coupling/brake-drum and steel-cover.

supplied by customer

supplied by SIBRE

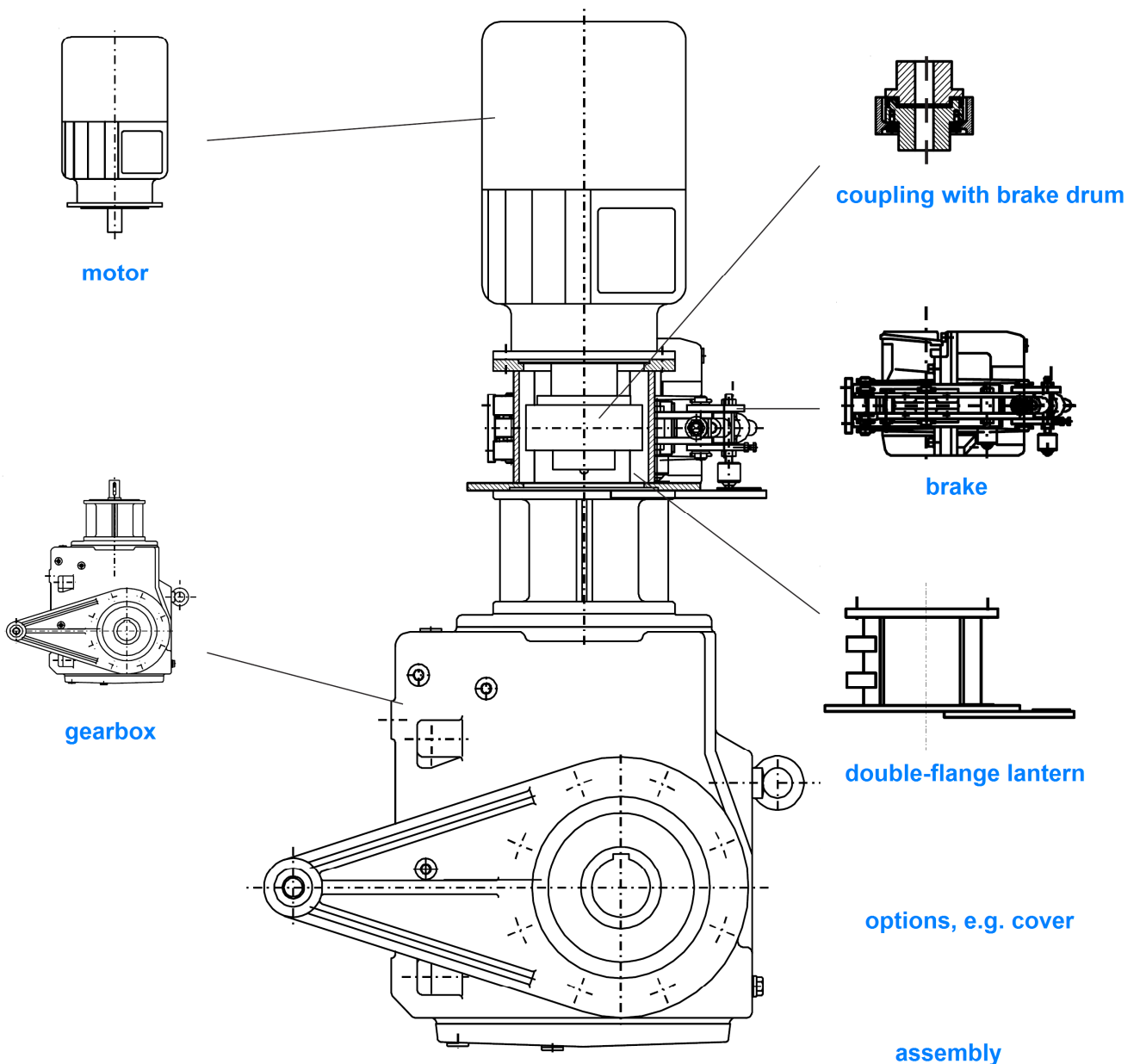

Alterations reserved

SIBRE Siegerland-Bremsen GmbH – Auf der Stücke 1-5 – D-35708 Haiger, Germany
Tel.: +49 2773 94000 – Fax: +49 2773 9400-10 – e-mail: info@sibre.de – www.sibre.de