

Description:

- The ABT 75/90 S R brake is an Active Brake, Hydraulically Applied; braking force produced by variation of hydraulic pressure.
- The ABT 75/90 S R brake consists of two independent caliper halves with opposite hydraulic cylinders. ABT brakes are suitable for horizontal and vertical brake discs under any angular displacement.
- The ABT 75/90 is equipped with removable lining retainer plates and sideways lining retraction springs.

Design Advantage:

- Compact and Robust construction
- Fast response time, fast braking for maximum safety
- Stainless steel piston
- High performance lining with stable friction coefficient
- Suitable for extreme low temperature application
- Long service life
- Easy maintenance
- Unique removable lining retainer plates provide easy lining replacement
- Lining retraction springs for guaranteed air gap between lining and disc when brake is open
- Suitable as rotor brake on the slow speed shaft

Application:

Stopping and / or Holding brake for Wind Power Generator

Alterations reserved

Siegerland Bremsen – Emde GmbH & Co. KG – Auf der Stücke 1-5 – D-35708 Haiger, Germany
Tel.: +49 2773 94000 – Fax: +49 2773 9400-10 – e-mail: info@sibre.de – www.sibre.de

Disc Brake / Rotor Caliper ABT 75 S R + ABT 90 S R

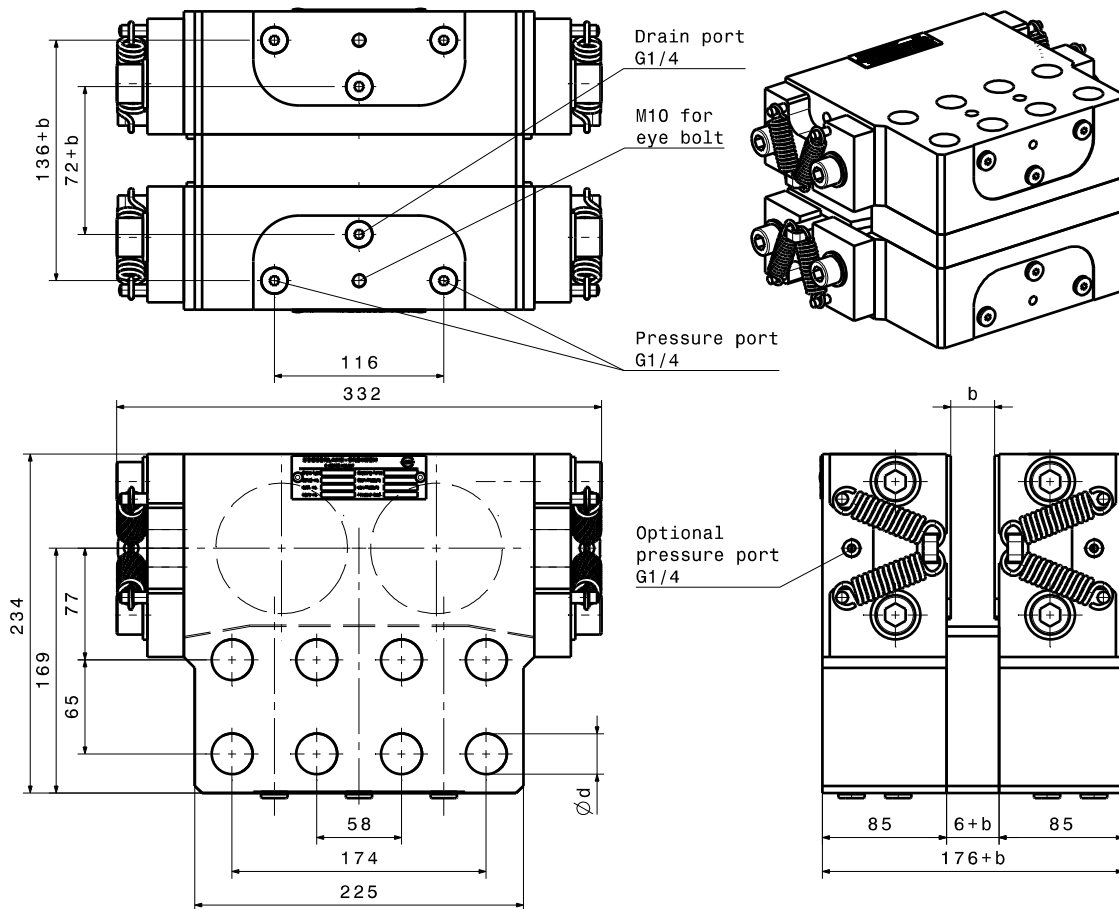

		ABT 75 S R	ABT 90 S R
Piston diameter	$\varnothing d_P$	75 mm	90 mm
Piston area each side	A_P	8835 mm ²	12723 mm ²
Operating pressure	p	160 bar	
Max. plant pressure	p_{max}	180 bar	
Oil volume per 1 mm stroke	V_{Oil}	18 cm ³	26 cm ³
Lining type		organic (sinter optional)	
Lining surface	A_L	250 cm ²	
Max. lining wear	s_L	7 mm	
Nominal friction static	μ	0.4	
Max. braking force	$F_{Br max}$	113 000 N	162 000 N
Minimum disc diameter	$\varnothing D_{min}$	1000 mm	
Disc thickness	b	20 – 70 mm	
Mounting boreholes	$\varnothing d$	$\varnothing 25$ mm	$\varnothing 28$ mm
Temperature range (for lower temperatures please contact us)	T	-40 °C to 70 °C	
Weight	m	75 kg	

Alterations reserved

Siegerland Bremsen – Emde GmbH & Co. KG – Auf der Stücker 1-5 – D-35708 Haiger, Germany
Tel.: +49 2773 94000 – Fax: +49 2773 9400-10 – e-mail: info@sibre.de – www.sibre.de

Example for mounting (b = 30)

	ABT 75 S R	ABT 90 S R
Mounting bolts M	M24-12.9	M27-12.9
Torque ($\mu = 0,14$)	1200 Nm	1800 Nm

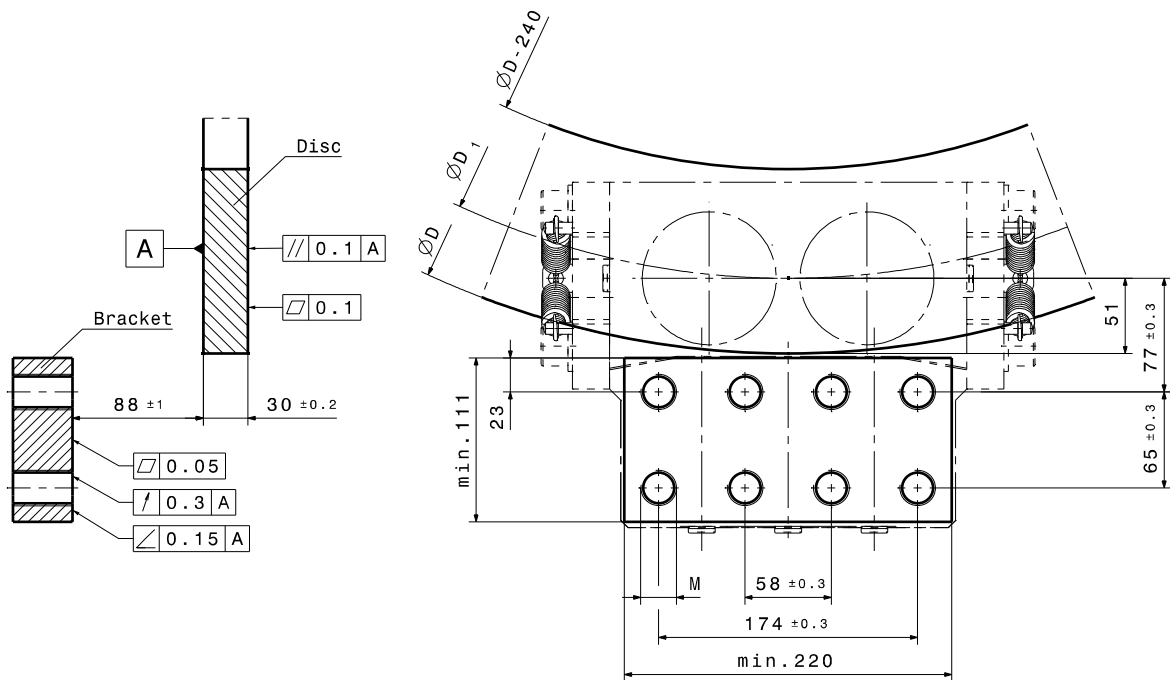

Calculation of Braking Torque

$$D_1 = D - 102$$

$$M_{Br} = F_{Br} \cdot \frac{D_1}{2} = 2 \cdot A_p \cdot p \cdot \mu \cdot \frac{D_1}{2} = 2 \cdot A_p \cdot p \cdot \mu \cdot \left(\frac{D}{2} - 51 \right)$$

Alterations reserved

Siegerland Bremsen – Emde GmbH & Co. KG – Auf der Stücker 1-5 – D-35708 Haiger, Germany
Tel.: +49 2773 94000 – Fax: +49 2773 9400-10 – e-mail: info@sibre.de – www.sibre.de