

Option
Endschalter

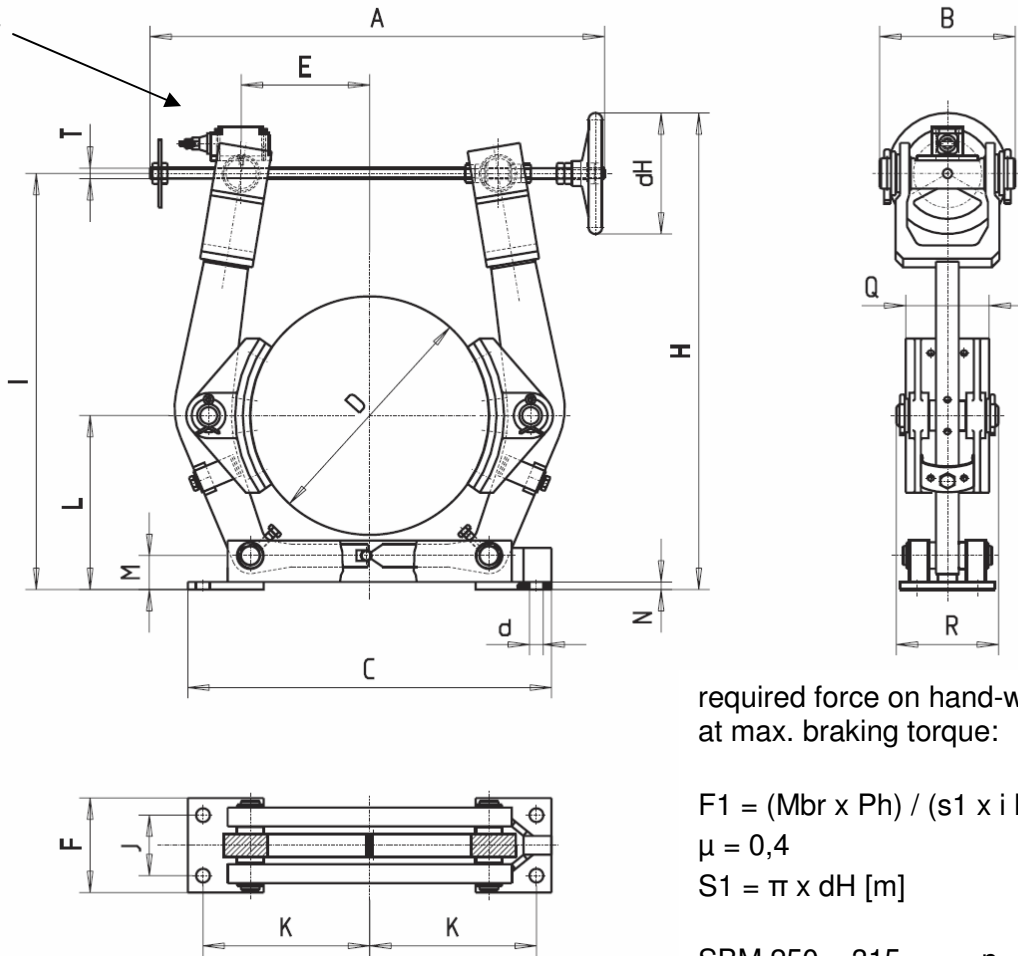

required force on hand-wheel
at max. braking torque:

$$F_1 = (M_{br} \times Ph) / (s_1 \times i \times \text{Hebel} \times \mu \times \eta \times D)$$

$$\mu = 0,4$$

$$S_1 = \pi \times dH \text{ [m]}$$

SBM 250 – 315 $\eta = 0,2485$

SBM 400 – 500 $\eta = 0,2225$

SBM 630 – 710 $\eta = 0,2225$

Bremsentyp Brake type	A	B	C	D	E	F	H	I	J	K	L	M	N	Q	R	T	dH	d	S1 [m]	i Hebel lever	Gew.steigung thread pitch PH [m]	Bremsmoment braking torque MBr [Nm]	Handkraft hand force N1 [N]
SBM 200	440	132	320	200	110	90	428	365	55	145	160	40	10	70	96	M14	125	14	0,3925	2,71	0,002	400	ca. 40
SBM 250	520	158	400	250	135	110	510	400	65	180	190	40	10	90	113	M14	140	18	0,4396	2,66	0,002	850	ca. 60
SBM 315	600	180	480	315	170	125	630	550	80	220	230	45	10	110	135	M14	160	18	0,5024	2,73	0,002	1700	ca. 80
SBM 400	730	213	600	400	212	160	692	602	100	270	280	47	12	140	167	M20	180	22	0,5652	2,38	0,0025	2750	ca. 160
SBM 500	870	267	710	500	262	190	830	730	130	325	340	50	13	180	202	M20	200	22	0,628	2,35	0,0025	5400	ca. 205
SBM 630	1000	332	880	630	327	250	985	860	170	400	420	60	15	225	244	M24	250	27	0,785	2,22	0,003	8200	ca. 250
SBM 710	1080	356	980	710	370	270	1085	965	190	450	470	65	15	255	276	M24	250	27	0,785	2,22	0,003	9400	ca. 255

The data sheet includes the limit switch for indication brake released, but no more accessories. Possible dimensional discrepancies are to be considered.