

option: lining wear compensator

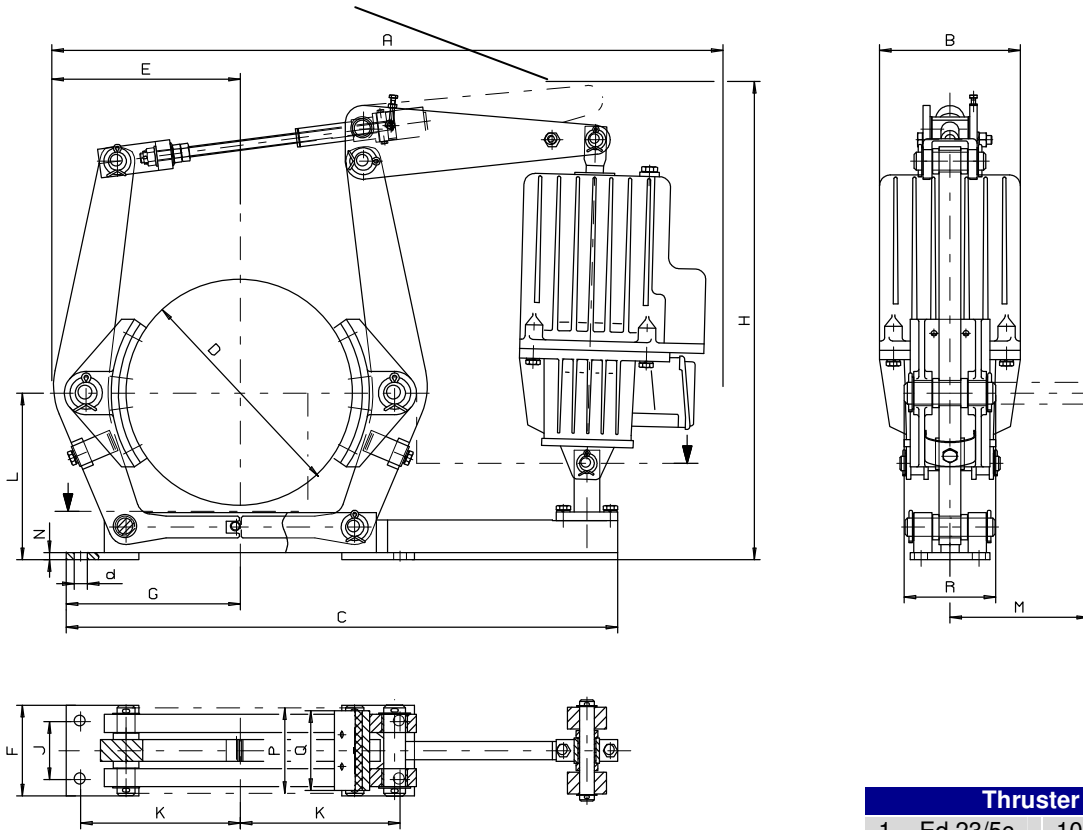

Thruster sizes

1 = Ed 23/5c	10 = EB 220-50c
2 = Ed 30/5c	20 = EB 300-50c
3 = Ed 50/6c	30 = EB 500-60c
4 = Ed 80/6c	40 = EB 800-60c
5 = Ed 121/6c	50 = EB 1250-60c
6 = Ed 201/6c	60 = EB 2000-60c
7 = Ed 301/6c	70 = EB 3000-60c

When ordering please advise:

- Brake Type and thruster e.g. TEc 250/23/5
- power supply voltage for thruster
- with or without lining wear compensator
- options

Brake-Type	Thruster size	Torque Range in Nm at $\mu = 0,4$	A	B	C	D	E	F	G	H	J	K	L	M	N	P	Q	R	d	kg*
TEc 200	1 / 10	245	640	160	515	200	170	90	160	475	55	145	160	115	10	75	70	96	14	16
	2 / 20	360	640	475																
TEc 250	1 / 10	265	760	160	625	250	210	110	200	550	65	180	190	133	10	95	90	113	18	27
	3 / 30	780	800	560																
TEc 315	1 / 10	345	885	160	735	315	260	125	240	650	80	220	230	160	10	118	110	135	18	46
	2 / 20	495	885	650																
	3 / 30	965	925	660																
TEc 400	4 / 40	1595	925	195	900	400	310	160	300	660	100	270	280	199	12	150	140	167	22	80
	2 / 20	515	1030	765																
	3 / 30	1010	1075	775																
TEc 500	4 / 40	1690	1075	195	1025	500	385	190	355	775	130	325	340	242	13	190	180	202	22	125
	5 / 50	2640	1075	870																
	3 / 30	1290	1225	870																
TEc 630	6 / 60	5130	1215	240	1190	630	465	250	440	870	170	400	420	295	15	236	225	244	27	200
	5 / 50	3170	1365	1000																
	6 / 60	5225	1365	1000																
TEc 710	7 / 70	7380	1365	240	1302	710	525	270	490	1000	190	450	470	332	15	265	255	276	27	262
	5 / 50	3650	1500	1100																
	6 / 60	5985	1500	240						1100										
	7 / 70	8460	1500	240						1100										

Alterations reserved

SIBRE Siegerland-Bremsen GmbH – Auf der Stücke 1-5 – D-35708 Haiger, Germany
Tel.: +49 2773 94000 – Fax: +49 2773 9400-10 – e-mail: info@sibre.de – www.sibre.de