

Description:

- The ABS 75-FC brake is an Active Brake, Hydraulically Applied; braking force produced by variation of hydraulic pressure.
- The ABS 75-FC brake is designed as a floating caliper with one hydraulic cylinder. ABS brakes are suitable for horizontal and vertical brake discs under any angular displacement.

Design Advantage:

- Compact and robust construction
- Fast response time, fast braking for maximum safety
- Stainless steel piston
- Sinter linings for high speed/high energy application
- Lining retraction springs ensure air gap between lining and disc, when brake is open
- Removable retainers allow easy change of linings
- Suitable for low temperature application
- Long service life
- Easy maintenance

Application:

Stopping and/or holding brake for wind turbines

Alterations reserved

Siegerland Bremsen – Emde GmbH & Co. KG – Auf der Stücker 1-5 – D-35708 Haiger, Germany
Tel.: +49 2773 94000 – Fax: +49 2773 9400-10 – e-mail: info@sibre.de – www.sibre.de

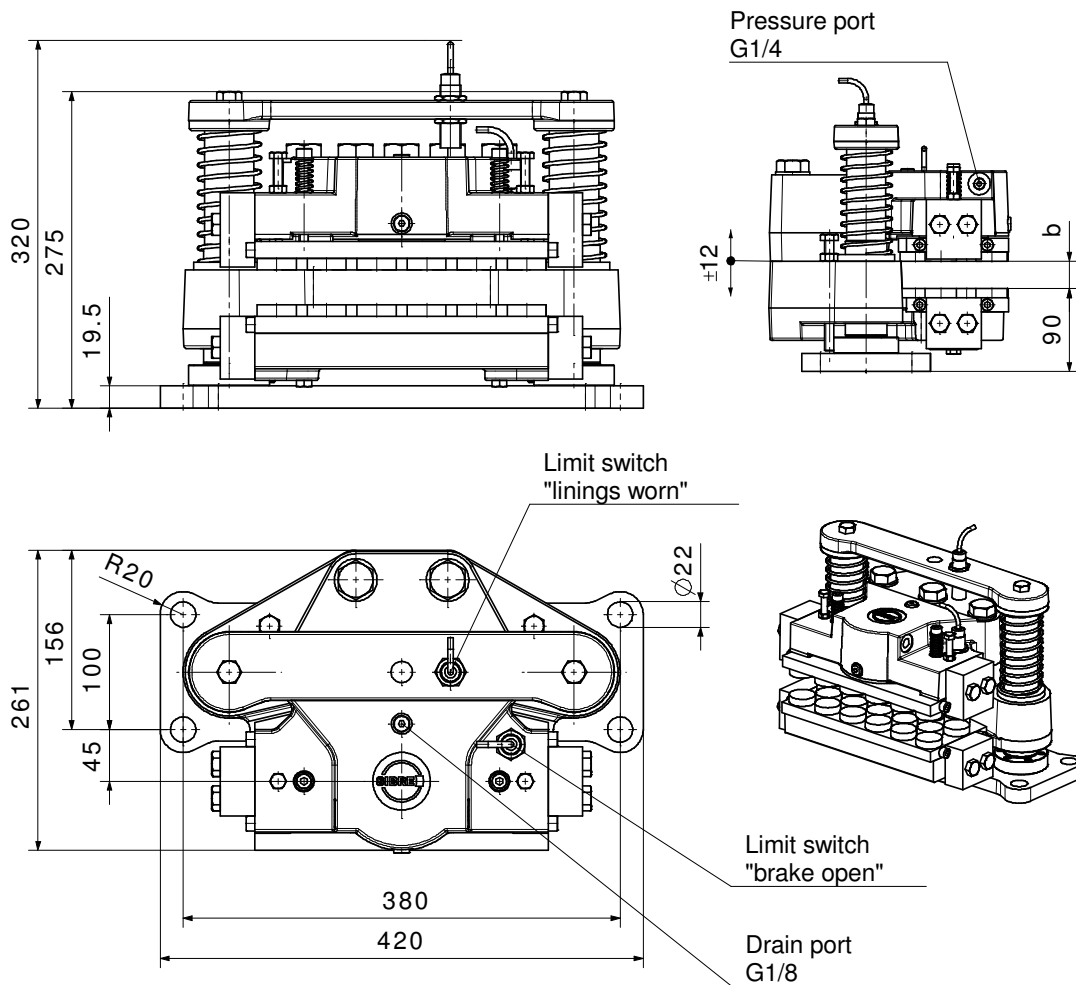

Piston diameter	\varnothing_{d_p}	75 mm
Piston area	A_p	4418 mm ²
Operating pressure	p	125 bar
Max. plant pressure	p_{max}	140 bar
Oil volume per 1 mm stroke	V_{oil}	4,4 cm ³
Lining type		sinter
Lining surface	A_L	200 cm ²
Max. lining wear	s_L	7 mm
Nominal friction coefficient	μ	0,4
Max. braking force	$F_{Br max}$	44000 N
Disc thickness	b	20 – 40 mm
Minimum disc diameter	D_{min}	500 mm
Floating range on guidance pins	r	± 12 mm
Temperature range (for lower temperatures please contact us)	T	-20 °C to 70 °C
Weight (complete)	m	80 kg

Alterations reserved

Siegerland Bremsen – Emde GmbH & Co. KG – Auf der Stücker 1-5 – D-35708 Haiger, Germany
Tel.: +49 2773 94000 – Fax: +49 2773 9400-10 – e-mail: info@sibre.de – www.sibre.de

Mounting

$$Y = 90 \pm 12$$

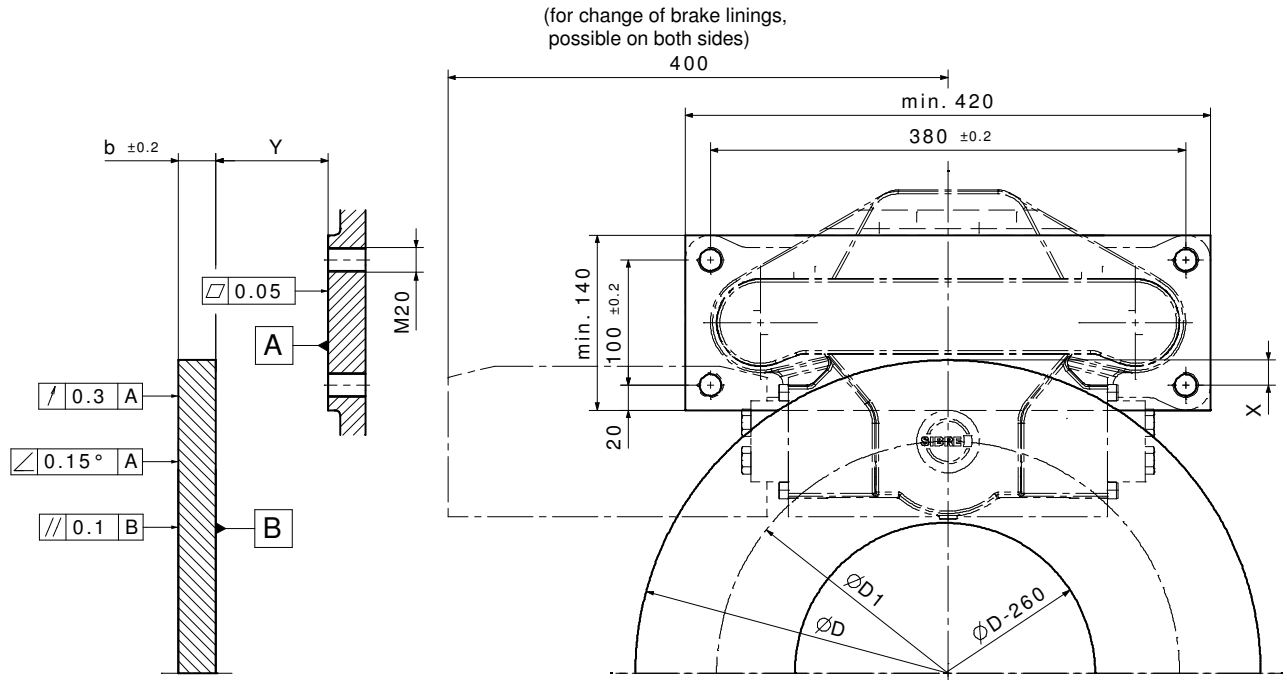

$\varnothing D$	$\varnothing D1$	X
$500 \leq \varnothing D < 1500$	$\varnothing D1 = \varnothing D - 130$	20
$1500 \leq \varnothing D < 1600$	$\varnothing D1 = \varnothing D - 126$	18
$1600 \leq \varnothing D < 2000$	$\varnothing D1 = \varnothing D - 120$	15
$2000 \leq \varnothing D < 4000$	$\varnothing D1 = \varnothing D - 110$	10

Calculation of Braking Torque

$$M_{Br} = F_{Br} \cdot \frac{D_1}{2} = 2 \cdot A_p \cdot p \cdot \mu \cdot \frac{D_1}{2} = A_p \cdot p \cdot \mu \cdot D_1$$

Alterations reserved

Siegerland Bremsen – Emde GmbH & Co. KG – Auf der Stücker 1-5 – D-35708 Haiger, Germany
Tel.: +49 2773 94000 – Fax: +49 2773 9400-10 – e-mail: info@sibre.de – www.sibre.de