



Trommelbremse / Drum Brake TE

nach / per DIN 15435
mit externer Bremsfeder und elektrohydraulischem Lüfter
with external spring and electrohydraulic thruster

M 900 10 00 E-DE-EN
Seite / page 1/1
11.1999



Tabelle / table 1

Lüftergröße / Thruster size	
1 = Ed 23/5	10 = EB 220/50
2 = Ed 30/5	20 = EB 300/50
3 = Ed 50/6	30 = EB 500/60
4 = Ed 80/6	40 = EB 800/60
5 = Ed 121/6	50 = EB 1250/60
6 = Ed 201/6	60 = EB 2000/60
7 = Ed 301/6	70 = EB 3000/60

Bei Bestellung bitte angeben:

- Bremsentyp und Lüftergröße z. B. TE200/23/5
- Anschlussspannung des Lüftergerätes
- mit oder ohne Verschleißnachstellung
- Zubehör

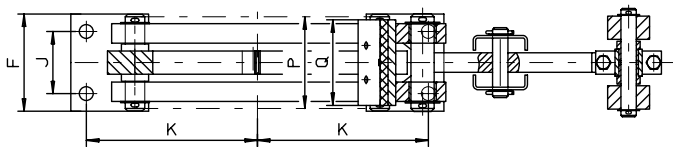
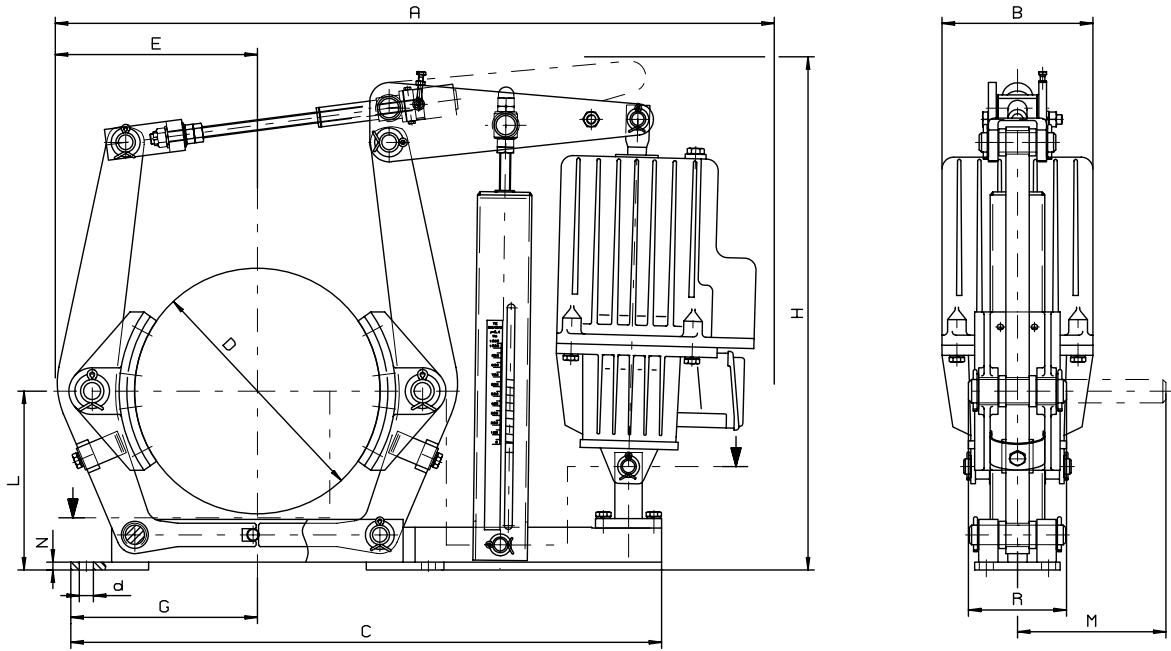
When ordering please advise:

- brake type and thruster size TE200/23/5
- power supply voltage of thruster
- with or without wear compensation
- optional features

Bremsentyp Brake type	Lüftergröße Thruster size siehe Tabelle 1 / see table 1	Mbr.(Nm) torque $\mu = 0,4$	A	B	C	D	E	F	G	H	J	K	L	M	N	P	Q	R	d	* kg																																																																																																																																																																																									
TE 200	1 / 10	50 - 300	640	160	515	200	170	90	160	475	55	145	160	115	10	75	70	96	14	19																																																																																																																																																																																									
	2 / 20	85 - 400	640	160						475											TE 250	1 / 10	40 - 325	760	160	625	250	210	110	200	550	65	180	190	133	10	95	90	113	18	30	2 / 20	40 - 450	760	160	550	3 / 30	100 - 850	800	195	560	TE 315	1 / 10	70 - 420	885	160	735	315	260	125	240	650	80	220	230	160	10	118	110	135	18	50	2 / 20	70 - 550	885	160	650	3 / 30	75 - 1050	925	195	660	4 / 40	90 - 1700	925	195	660	TE 400	2 / 20	80 - 575	1030	160	900	400	310	160	300	765	100	270	280	199	12	150	140	167	22	85	3 / 30	100 - 1100	1075	195	775	4 / 40	100 - 1800	1075	195	775	5 / 50	125 - 2750	1075	240	775	TE 500	3 / 30	200 - 1400	1225	195	1025	500	385	190	355	870	130	325	340	242	13	190	180	202	22	130	4 / 40	200 - 2200	1225	195	870	5 / 50	200 - 3400	1215	240	870	6 / 60	200 - 5400	1215	240	870	TE 630	5 / 50	500 - 3300	1365	240	1190	630	465	250	440	1000	170	400	420	295	15	236	225	244	27	206	6 / 60	500 - 5500	1365	240	1000	7 / 70	500 - 8200	1365	240	1000	TE 710	5 / 50	500 - 3800	1500	240	1302	710	525	270	490	1100	190	450	470	332
TE 250	1 / 10	40 - 325	760	160	625	250	210	110	200	550	65	180	190	133	10	95	90	113	18	30																																																																																																																																																																																									
	2 / 20	40 - 450	760	160						550																																																																																																																																																																																																			
	3 / 30	100 - 850	800	195						560																																																																																																																																																																																																			
TE 315	1 / 10	70 - 420	885	160	735	315	260	125	240	650	80	220	230	160	10	118	110	135	18	50																																																																																																																																																																																									
	2 / 20	70 - 550	885	160						650																																																																																																																																																																																																			
	3 / 30	75 - 1050	925	195						660																																																																																																																																																																																																			
	4 / 40	90 - 1700	925	195						660																																																																																																																																																																																																			
TE 400	2 / 20	80 - 575	1030	160	900	400	310	160	300	765	100	270	280	199	12	150	140	167	22	85																																																																																																																																																																																									
	3 / 30	100 - 1100	1075	195						775																																																																																																																																																																																																			
	4 / 40	100 - 1800	1075	195						775																																																																																																																																																																																																			
	5 / 50	125 - 2750	1075	240						775																																																																																																																																																																																																			
TE 500	3 / 30	200 - 1400	1225	195	1025	500	385	190	355	870	130	325	340	242	13	190	180	202	22	130																																																																																																																																																																																									
	4 / 40	200 - 2200	1225	195						870																																																																																																																																																																																																			
	5 / 50	200 - 3400	1215	240						870																																																																																																																																																																																																			
	6 / 60	200 - 5400	1215	240						870																																																																																																																																																																																																			
TE 630	5 / 50	500 - 3300	1365	240	1190	630	465	250	440	1000	170	400	420	295	15	236	225	244	27	206																																																																																																																																																																																									
	6 / 60	500 - 5500	1365	240						1000																																																																																																																																																																																																			
	7 / 70	500 - 8200	1365	240						1000																																																																																																																																																																																																			
TE 710	5 / 50	500 - 3800	1500	240	1302	710	525	270	490	1100	190	450	470	332	15	265	255	276	27	268																																																																																																																																																																																									
	6 / 60	500 - 6300	1500	240						1100																																																																																																																																																																																																			
	7 / 70	500 - 9400	1500	240						1100																																																																																																																																																																																																			

*** Gewicht ohne Lüftergerät
Weight without thruster**

In der Massblattdarstellung ist die Verschleißnachstellung, jedoch kein weiteres Zubehör enthalten.
Eventuelle Maßabweichungen sind zu berücksichtigen.
The data sheet includes the wear compensation but no more accessories. Possible dimensional discrepancies are to be considered.

Siegerland Bremsen
Auf der Stücke 1 - 5
35 708 HAIGER
GERMANY

Fon: +49 (0)27 73 / 9400-0
Fax: +49 (0)27 73 / 9400-10
e-mail: info@sibre.de
internet: http://www.sibre.de

Konstruktionsänderungen vorbehalten! / Alterations reserved!

M 900 20 00 E-DE-EN
Seite / page 1/1
08.2001

Trommelbremse / Drum Brake TEc

nach / per DIN 15435
mit elektrohydraulischem Lüfter und interner Bremsfeder
for electrohydraulic thruster and internal spring



Tabelle / table 1

Lüftergerät Größe / Thruster size	
1 = Ed 23/5c	10 = EB 220/50c
2 = Ed 30/5c	20 = EB 300/50c
3 = Ed 50/6c	30 = EB 500/60c
4 = Ed 80/6c	40 = EB 800/60c
5 = Ed 121/6c	50 = EB 1250/60c
6 = Ed 201/6c	60 = EB 2000/60c
7 = Ed 301/6c	70 = EB 3000/60c

Bei Bestellung bitte angeben:

- Bremsentyp und Lüftergerät Größe z. B. TEc200/23/5c
- Anschlussspannung des Lüftergerätes
- mit oder ohne Verschleißnachstellung
- Zubehör

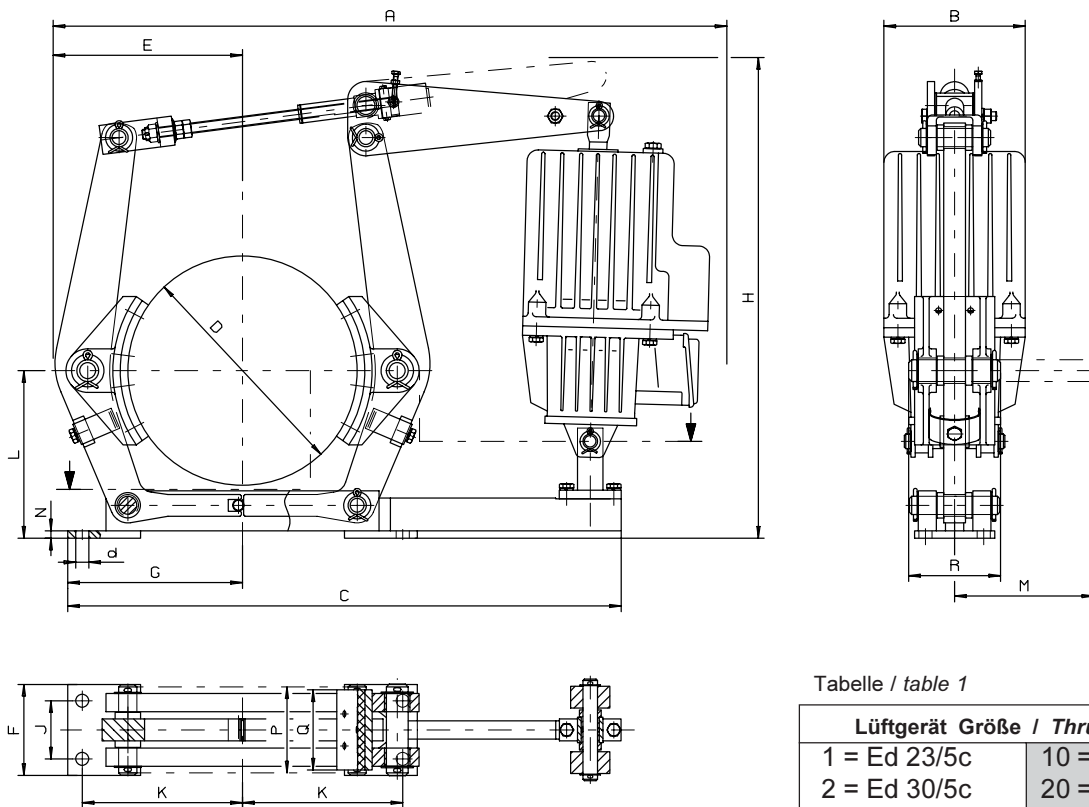
When ordering please advice:

- brake type and thruster size TEc200/23/5c
- power supply voltage of thruster
- with or without wear compensation
- optional features

Bremsentyp Brake type	Lüftergerät Größe Thruster size siehe Tabelle 1 / see table 1	Mbr.(Nm) torque $\mu = 0,4$	A	B	C	D	E	F	G	H	J	K	L	M	N	P	Q	R	d	* kg																																																																																																																																																																																									
TEc 200	1 / 10	245	640	160	515	200	170	90	160	475	55	145	160	115	10	75	70	96	14	16																																																																																																																																																																																									
	2 / 20	360	640	160						475											TEc 250	1 / 10	265	760	160	625	250	210	110	200	550	65	180	190	133	10	95	90	113	18	27	2 / 20	405	760	160	550	3 / 30	780	800	195	560	TEc 315	1 / 10	345	885	160	735	315	260	125	240	650	80	220	230	160	10	118	110	135	18	46	2 / 20	495	885	160	650	3 / 30	965	925	195	660	4 / 40	1595	925	195	660	TEc 400	2 / 20	515	1030	160	900	400	310	160	300	765	100	270	280	199	12	150	140	167	22	80	3 / 30	1010	1075	195	775	4 / 40	1690	1075	195	775	5 / 50	2640	1075	240	775	TEc 500	3 / 30	1290	1225	195	1025	500	385	190	355	870	130	325	340	235	13	190	180	202	22	125	4 / 40	2060	1225	195	870	5 / 50	3265	1215	240	870	6 / 60	5130	1215	240	870	TEc 630	5 / 50	3170	1365	295	1190	630	465	250	440	1000	170	400	420	295	15	236	225	244	27	200	6 / 60	5225	1365	295	1000	7 / 70	7380	1365	295	1000	TEc 710	5 / 50	3650	1500	240	1302	710	525	270	490	1100	190	450	470	332
TEc 250	1 / 10	265	760	160	625	250	210	110	200	550	65	180	190	133	10	95	90	113	18	27																																																																																																																																																																																									
	2 / 20	405	760	160						550																																																																																																																																																																																																			
	3 / 30	780	800	195						560																																																																																																																																																																																																			
TEc 315	1 / 10	345	885	160	735	315	260	125	240	650	80	220	230	160	10	118	110	135	18	46																																																																																																																																																																																									
	2 / 20	495	885	160						650																																																																																																																																																																																																			
	3 / 30	965	925	195						660																																																																																																																																																																																																			
	4 / 40	1595	925	195						660																																																																																																																																																																																																			
TEc 400	2 / 20	515	1030	160	900	400	310	160	300	765	100	270	280	199	12	150	140	167	22	80																																																																																																																																																																																									
	3 / 30	1010	1075	195						775																																																																																																																																																																																																			
	4 / 40	1690	1075	195						775																																																																																																																																																																																																			
	5 / 50	2640	1075	240						775																																																																																																																																																																																																			
TEc 500	3 / 30	1290	1225	195	1025	500	385	190	355	870	130	325	340	235	13	190	180	202	22	125																																																																																																																																																																																									
	4 / 40	2060	1225	195						870																																																																																																																																																																																																			
	5 / 50	3265	1215	240						870																																																																																																																																																																																																			
	6 / 60	5130	1215	240						870																																																																																																																																																																																																			
TEc 630	5 / 50	3170	1365	295	1190	630	465	250	440	1000	170	400	420	295	15	236	225	244	27	200																																																																																																																																																																																									
	6 / 60	5225	1365	295						1000																																																																																																																																																																																																			
	7 / 70	7380	1365	295						1000																																																																																																																																																																																																			
TEc 710	5 / 50	3650	1500	240	1302	710	525	270	490	1100	190	450	470	332	15	265	255	276	27	262																																																																																																																																																																																									
	6 / 60	5985	1500	240						1100																																																																																																																																																																																																			
	7 / 70	8460	1500	240						1100																																																																																																																																																																																																			

***Gewicht ohne Lüftergerät
Weight without thruster**

In der Massblattdarstellung ist die Verschleißnachstellung, jedoch kein weiteres Zubehör enthalten. Eventuelle Maßabweichungen sind zu berücksichtigen. The data sheet includes the wear compensation but no more accessories. Possible dimensional discrepancies are to be considered.

Siegerland Bremsen
Auf der Stücke 1 - 5
35 708 HAIGER
GERMANY

Fon: +49 (0)27 73 / 9400-0
Fax: +49 (0)27 73 / 9400-10
e-mail: info@sibre.de
internet: http://www.sibre.de

Konstruktionsänderungen vorbehalten! / Alterations reserved!