

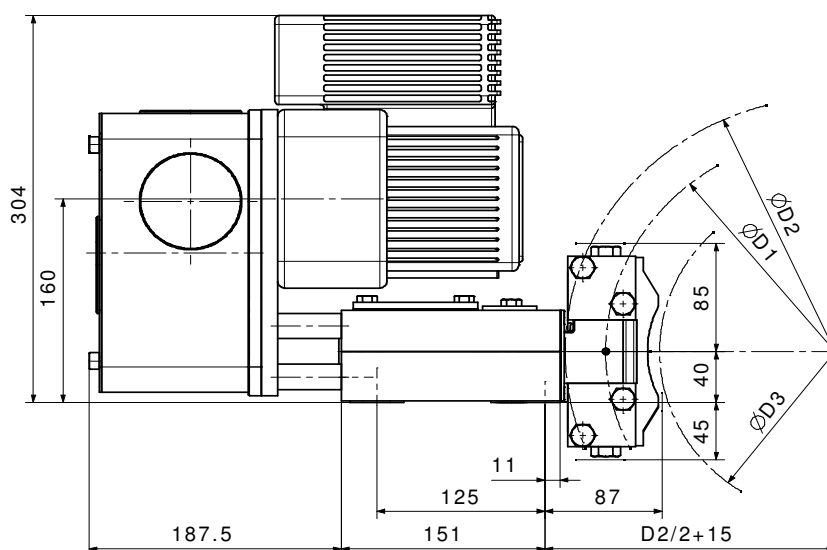

Kompakt-Scheibenbremse
Compact calliper Brake
CB8-E

M 1501 320 E-DE/EN
Seite / page 1 / 1
03.2007

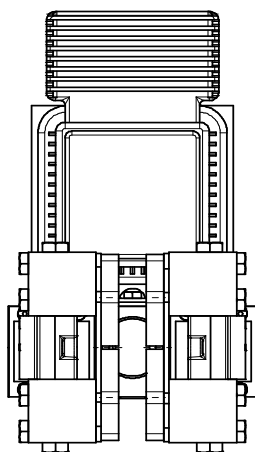
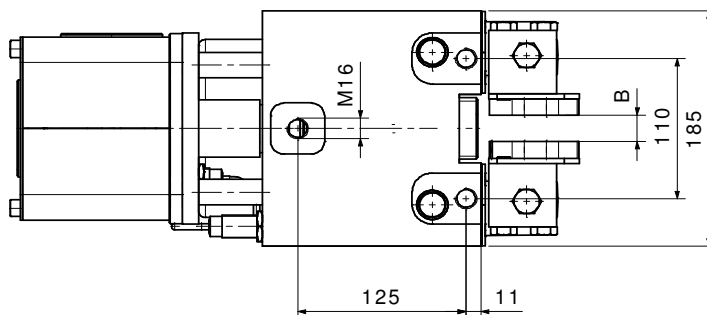
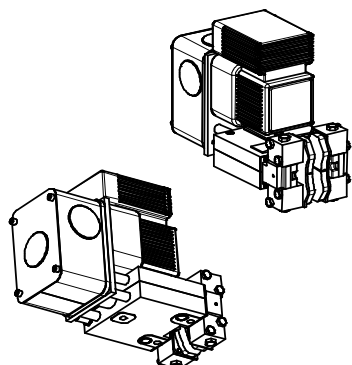

optional Handlüftung, Schalter „auf“ und „Verschleiß“

optional: manual release, switch „open“ & „wear“

B = Scheibenbreite in mm, Standard = 20 mm
optional: 12,5; 12,7; 16; 25; 30
Ø D1 = mittlerer Reibdurchmesser in mm
= ØD2 – 60 mm
Ø D2 = äußerer Scheibendurchmesser in mm
Ø D3 = max. Naben- oder Kupplungsdurchmesser in mm
= ØD2 – 140 mm

B = disc width in mm, standard = 20 mm
optional: 12,5; 12,7; 16; 25; 30
Ø D1 = average friction diameter in mm
= ØD2 – 60 mm
Ø D2 = outer disc diameter in mm
Ø D3 = max. hub or coupling diameter in mm
= ØD2 – 140 mm

Beläge Standard: Größe 100 cm², organisch
optional: Größe 50 cm², organisch
optional: Größe 100 cm², Sinter

Linings standard: size 100 cm², organic
optional: size 50 cm², organic
optional: size 100 cm², sinter

Bremsmoment in Nm ($\mu=0,4$) auf Scheiben-Ø D2, einstellbar von – bis braking torque in Nm ($\mu=0,4$) on disc-Ø D2, adjustable from – to							
	Ø 200	Ø 250	Ø 315	Ø 400	Ø 500	Ø 630	Ø 710
CB8-E1-100	60-630	80-850	100-1140	140-1510	180-1950	230-2530	260-2880

Siegerland Bremsen
Auf der Stücke 1 - 5
35 708 HAIGER
GERMANY

Fon: +49 (0)27 73 / 9400-0
Fax: +49 (0)27 73 / 9400-10
e-mail: info@sibre.de
internet: http://www.sibre.de